

Rezoning and Development Permit with Variances Application for 1628 Edgware Road

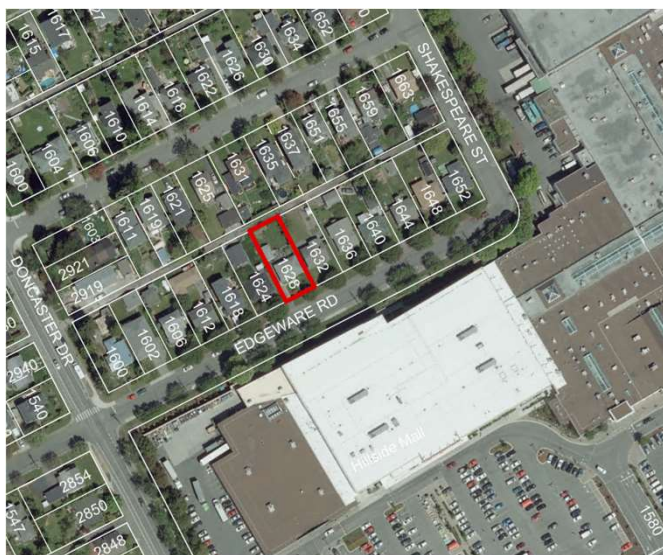

Aerial



Aerial View

3

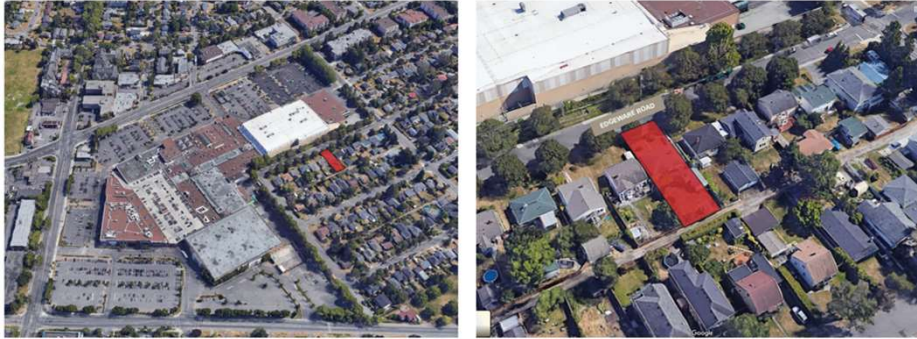

3

Site Context

4



Subject Property



Edgeware Road



Rear Lane



Hillside Mall



4

Policy Context

5



5

Streetscape

6



Max. height
in R1-B Zone
(7.6 m)



6

Front View Artistic Render

7



7

Existing Site Plan

8

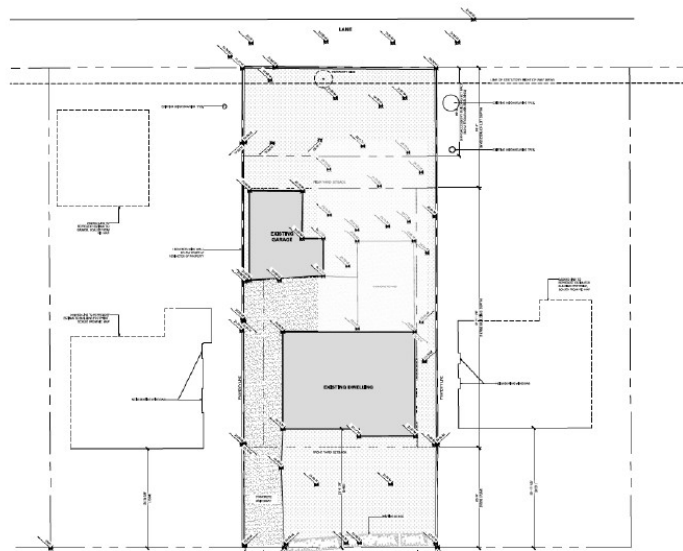

8

Proposed Site Plan

9

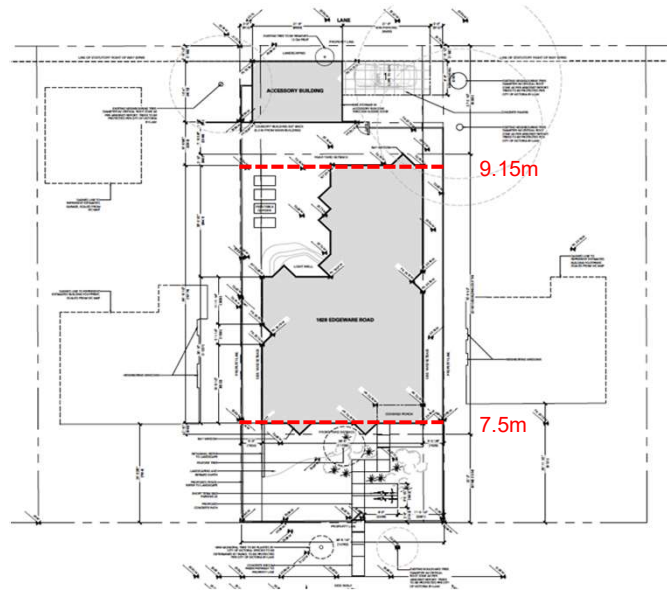

9

Window Placement

10

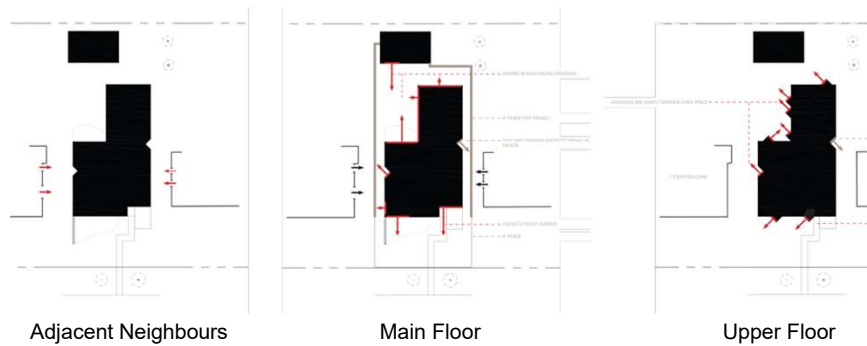

10

Basement Plan

11

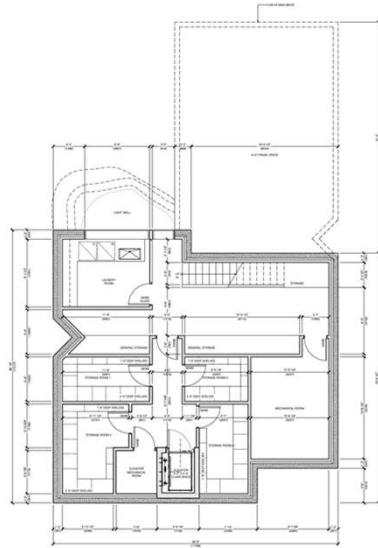

11

Main Level Plan

12

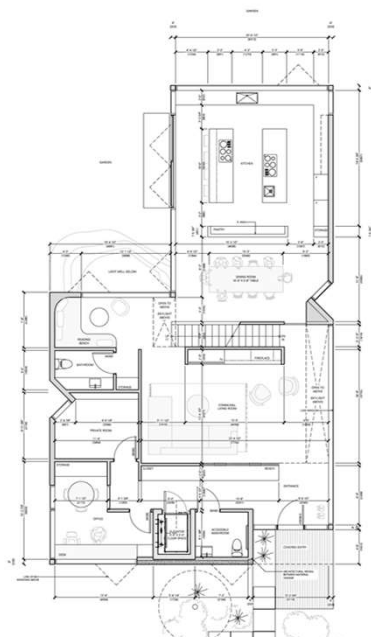

12

Upper Level Plan

13

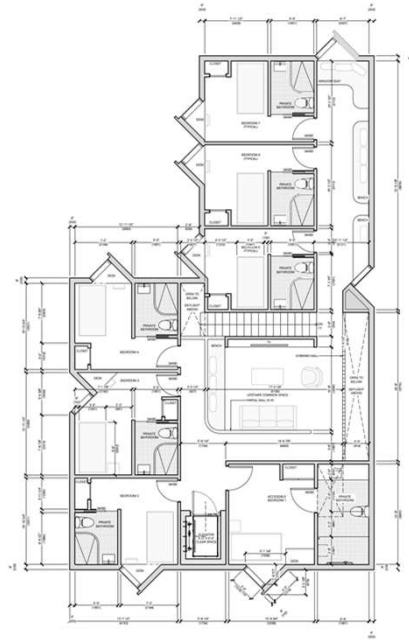

13

Accessory Building Plan

14

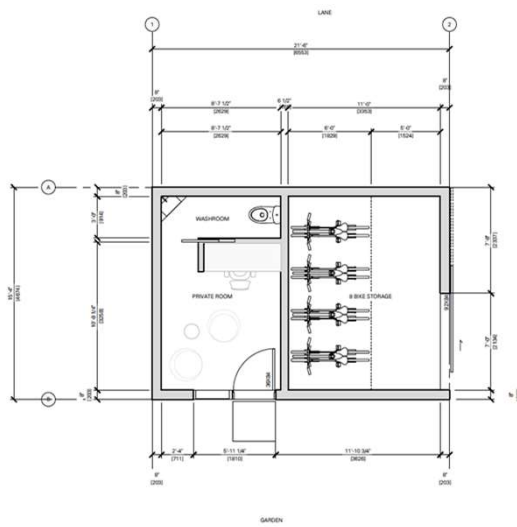

14

South Elevation (Front)

15

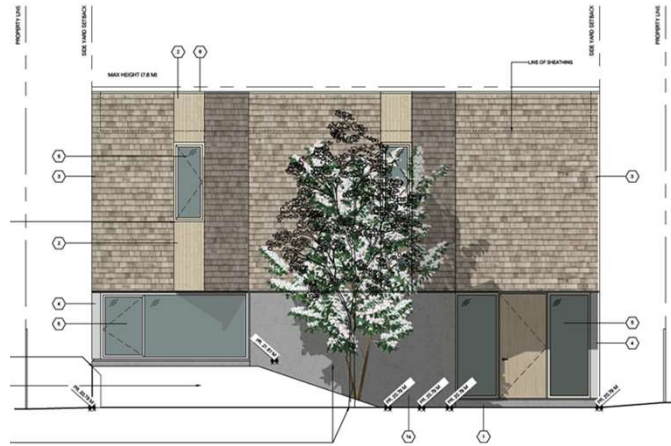

15

North Elevation (Rear)

16

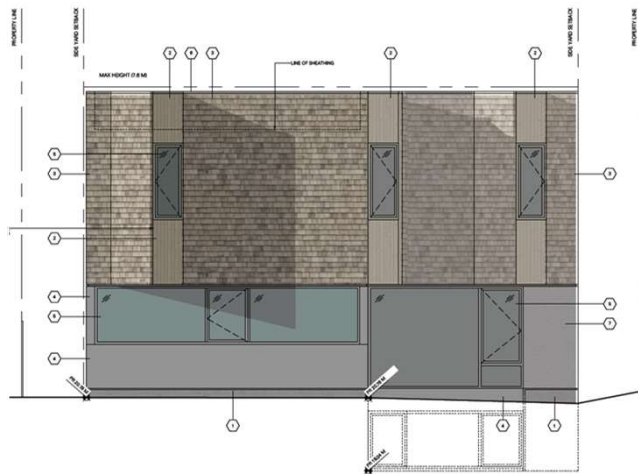

16

East Elevation (Side)

17

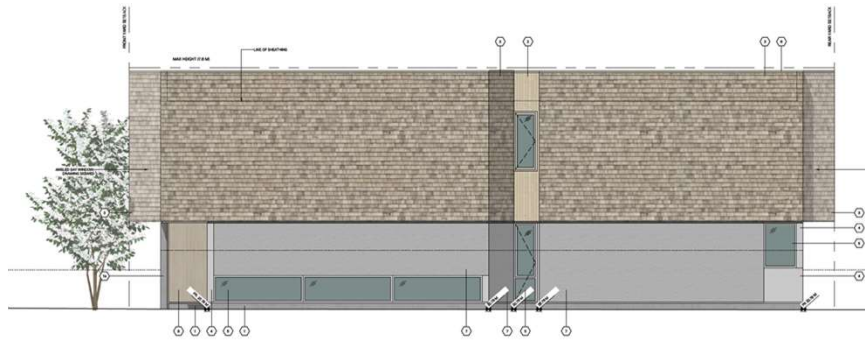

17

West Elevation (Side)

18

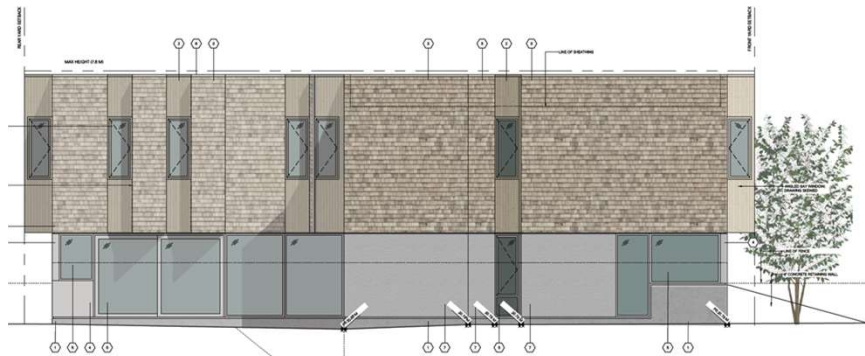

18

Material Board

19

1 EXPOSED CONCRETE

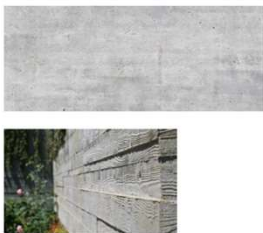

2 STAINED T&E WOOD SONG



3 STAINED CLEAR SHINGLES



4 SMOOTH PANEL, PAINTABLE & COLORABLE FINISHES FOLLOWUP TO MATCH LOCATION



5 SMOOTH WOOD PANEL



6 TEXTURED BOARD FORM CONCRETE



7 WOOD SLATED





19

Landscape Site Plan

20

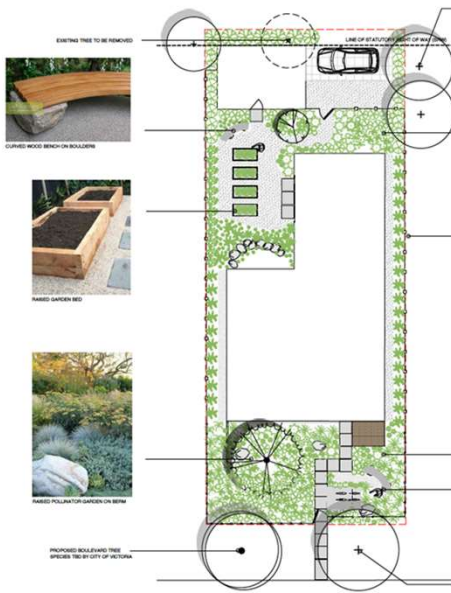

EXISTING TREE TO BE REMOVED

EXISTING NEIGHBORING TREE

LINE OF STATUTE/PROPERTY LINE

EXISTING BOLLARD TREE

PROPOSED BOLLARD TREE

EXISTING BOLLARD TREE



CURVED WOOD BENCH ON BOLLARD

BASED GARDEN BED

BASED POLLINATOR GARDEN ON BENCH

SOFT PERENNIAL GARDEN

PICKET FENCE AND DETAIL

#107 FENCE SECTION

#108 FENCE SECTION WITH 10' MID RAIL

POLLINATOR GARDEN

CURVED WOOD BENCH ON BOLLARD

Trees to be removed on site: 1
New trees proposed on site: 2
New trees proposed off-site: 1
Net Gain: +2



20

Concept

21



Front



Interior



Rear

