



2021

CITY OF VICTORIA | Parks, Recreation and Facilities

# Third-Party Public Infrastructure Proposals

Committee of the Whole  
November 4, 2021



1

## Purpose

To provide Council with information about proposals from community groups for public infrastructure on municipal property, and options for decision-making

Third-Party Public Infrastructure Proposals ► November 4, 2021



2

## Third-Party Contribution Program

- New City program to assist Council with the review, approval, and prioritization of community proposals as part of the annual Financial Planning process
- Program will include a guideline outlining the procedure, timelines, and requirements for community proposals
- Although projects may not require a capital investment, any new asset the City acquires will have ongoing operational responsibilities and risks

Third-Party Public Infrastructure Proposals ► November 4, 2021



3

## Skateable Bench At Vic West Park

**Description:** Custom designed concrete bench located at the skate park, proposed by Toby family

**Benefits:**

- New and unique recreation amenity that supports and enhances the user experience

**Risks:**

- Safety - custom park amenity that may present risk of injury

**Resource implications:**

- Installation coordination and communications
- On-going maintenance impacts less than \$1,000 per year

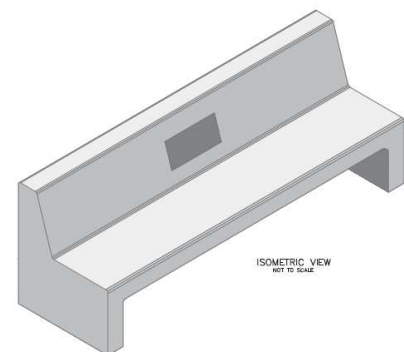

Third-Party Public Infrastructure Proposals ► November 4, 2021



4

## Entry Gates At Ross Bay Cemetery

**Description:** Custom stone columns and cast-iron entry gates, proposed by the Old Cemetery Society

**Benefits:**

- Enhances park identity and heritage character
- Supports neighbourhood placemaking

**Risks:**

- Third-party development on City land
- Complex site involving utilities, graves, transportation, legal considerations

**Resource implications:**

- Professional coordination to manage risks, ensure work meets engineering and regulatory requirements
- Operating budget of \$2,000 to be added once complete

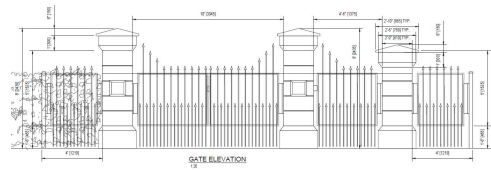

Third-Party Public Infrastructure Proposals ▶ November 4, 2021



5

## Lime Bay Park Beach Enhancement

**Description:** Marine and shoreline enhancement, proposed by Peninsula Streams Society

**Benefits:**

- Shoreline improvements will enhance habitat for foraging fish
- Restoration of a culturally significant site to the Lekwungen

**Risks:**

- Third-party development on City, provincial lands
- Marine construction has the potential to negatively impact the natural environment

**Resource implications:**

- Professional coordination to manage risks, ensure work meets engineering and regulatory requirements



Third-Party Public Infrastructure Proposals ▶ November 4, 2021



6

## Fifth Street Playground

**Description:** Playground donation and park development, proposed by Aryze Developments

**Benefits:**

- Donation of a playground amenity worth an estimated \$225,000
- Enhancement of underutilized greenspace

**Risks:**

- Development of lands currently managed by SD61 requires special legal arrangement
- Concept design does not meet City standards

**Resource implications:**

- Staff capacity required to support discussions with SD61, update concept designs and park plan



Third-Party Public Infrastructure Proposals ▶ November 4, 2021



7

## Options and Implications

The Draft 2022 Financial Plan has been developed without the resource implications for these proposals.

Staff have identified potential adjustments, where required, to accommodate these proposals if desired by Council:

- *Deferral of **Vic West Skatepark Lighting project** to 2023 to support **Entry Gates project***
- *Deferral of **Banfield Park Shoreline Access Feasibility Study** to 2023 to support **Lime Bay project***
- *Deferral of **new Downtown Playground project** to 2023 to support **Fifth St Playground project***

Other major park projects proposed in Draft 2022 Financial Plan:

- Natural Areas Restoration Plans
- Topaz Park Phase 2 Improvements
- Park Acquisition Plan
- Bushby Park Playground Renewal
- Beacon Hill Park Transportation, Circulation, Accessibility Study

Third-Party Public Infrastructure Proposals ▶ November 4, 2021



8

## Recommendations

That Council direct staff to:

1. Prepare the necessary agreement with the Toby Family to install the proposed Skateable Bench at Vic West Park;
2. Update the 2022 Financial Plan and reallocate the necessary staff resources required to support the proposal from the Old Cemeteries Society for entry gates at Ross Bay Cemetery and add \$2,000 to the 2023 Financial Plan for ongoing operating expenses;
3. Update the 2022 Financial Plan and reallocate the necessary staff resources required to support the proposal from the Peninsula Streams Society for the Lime Bay Park Beach Enhancement;
4. Update the 2022 Financial Plan and reallocate the necessary staff resources required to formalize the necessary arrangements with School District 61 and Aryze Developments to support the Fifth Street Playground on the City land located at 2550-2560 Fifth Street and report back to Council.

Third-Party Public Infrastructure Proposals ► November 4, 2021

