



VICTORIA REGENT
WATERFRONT HOTEL & SUITES

April 8, 2021

Liquor and Cannabis Regulation Branch
PO Box 9292 Stn Provincial Govt
Victoria, BC V8W 9J8 Canada

Dear Sir or Madam,

The Victoria Regent Waterfront Hotel & Suites has been operating for close to 40 years. We currently hold a Food Primary License (#122089), but due to Covid-19, we will be shutting down our Café and restore the unit back to a regular hotel suite. We have always offered in-room minibars that include the following items: wine, beer, soft drinks, chocolate bars, chips and nuts. We are applying for a Liquor Primary License in order to be able to continue offering this service to our guests.

Minibars are located in the hotel rooms and suites and are accessible by guests 24 hours/day. We do not allow minors to book rooms or check into the hotel without an adult companion. We do not have an onsite bar, restaurant and/or lounge. We do not have conference and meeting rooms or a pool.

We are located on Wharf St, at the bottom of Yates St, in downtown Victoria. Our neighbourhood is comprised of a mix of residential and commercial buildings. In-room minibars offer no potential for noise and other disturbances to our neighbours.

If you require any further information, please do not hesitate to contact us by phone at 250-386-2211 or by email at elaine@victoriaregent.com.

Sincerely,



Elaine Azevedo
General Manager

THE VICTORIA REGENT HOTEL

1234 WHARF STREET, VICTORIA, BRITISH COLUMBIA, CANADA V8W 3H9
PH: 250.386.2211 FAX: 250.386.2622 TOLL FREE: 1.800.663.7472 WEB: WWW.VICTORIAREGENT.COM

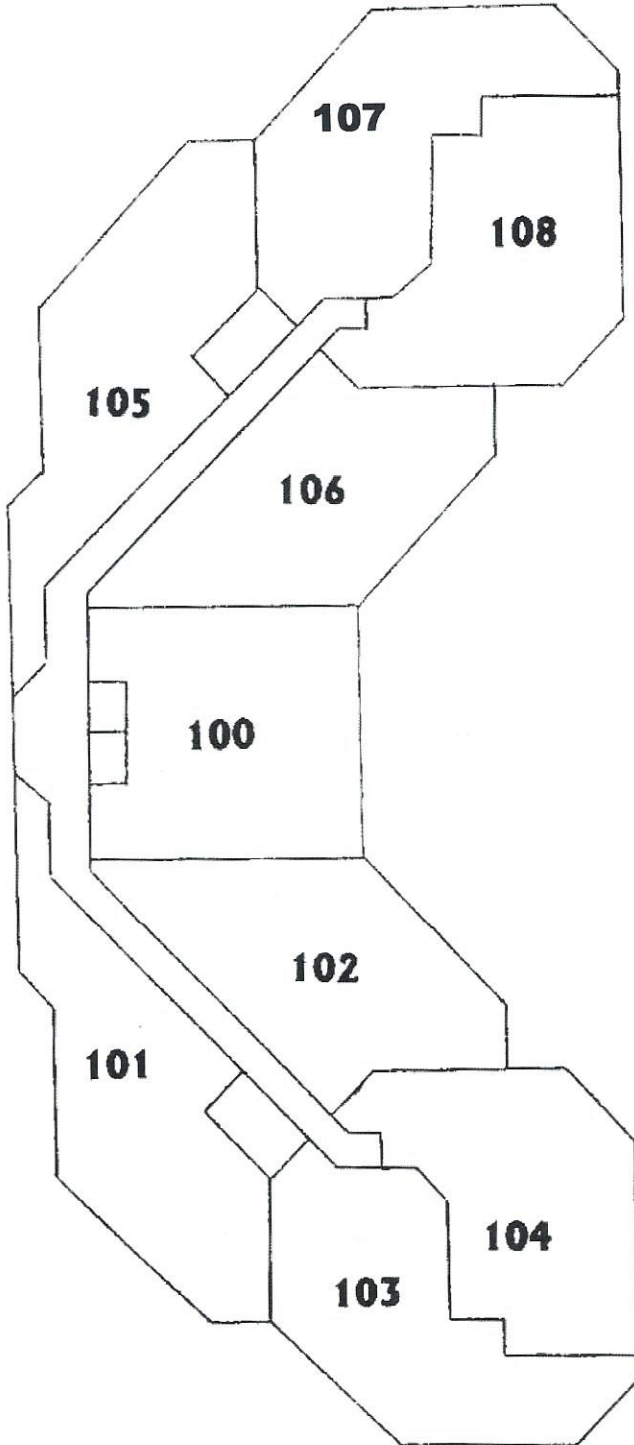

VICTORIA REGENT
WATERFRONT HOTEL & SUITES





VICTORIA REGENT
WATERFRONT HOTEL & SUITES

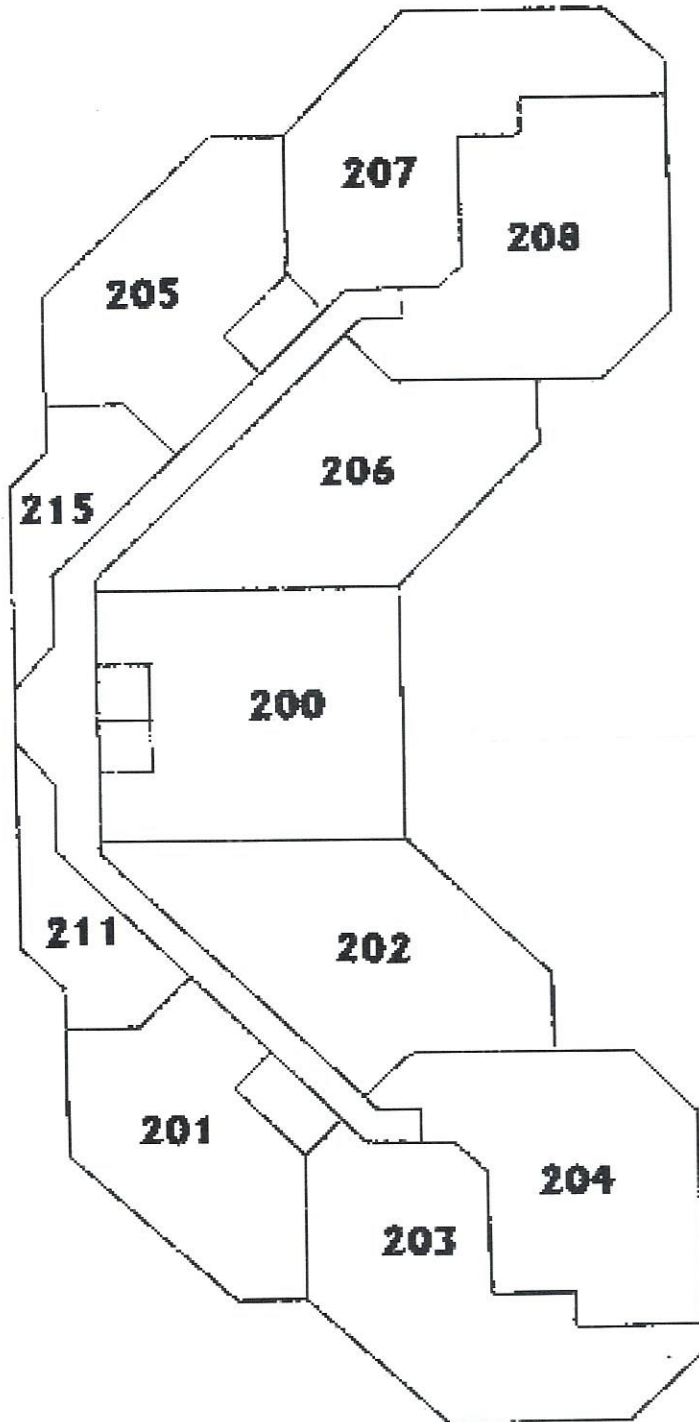



VICTORIA REGENT
WATERFRONT HOTEL & SUITES

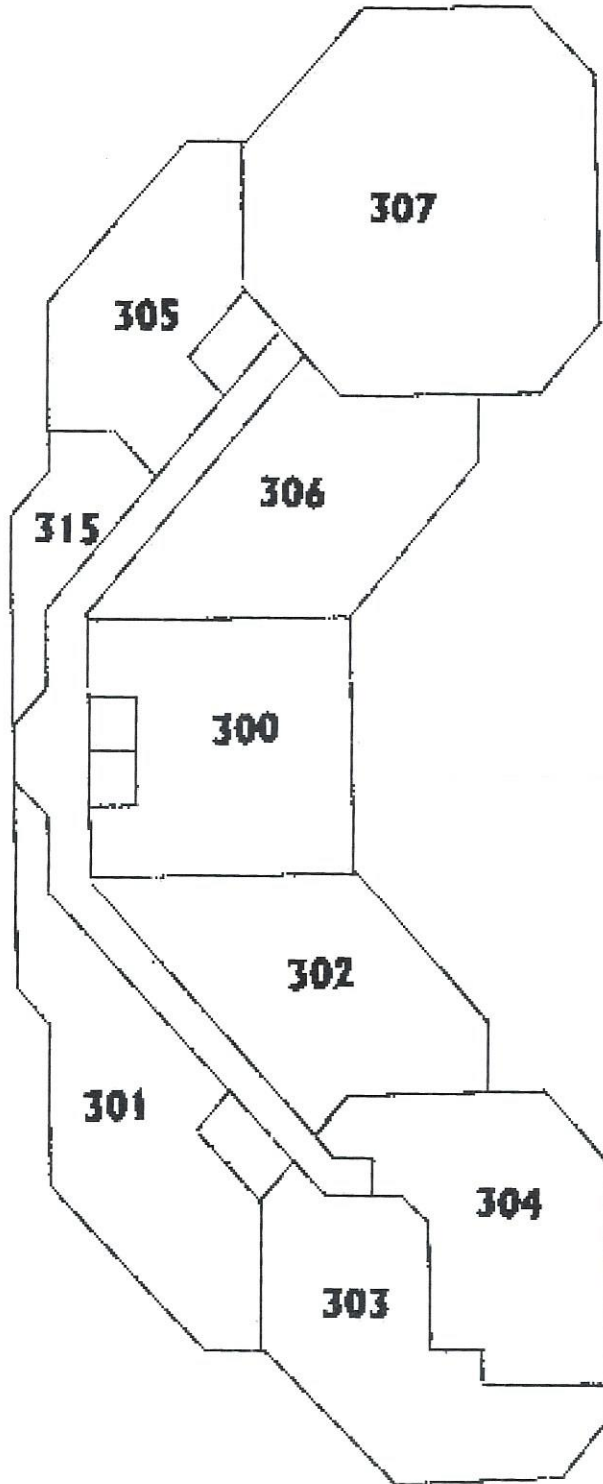



VICTORIA REGENT
WATERFRONT HOTEL & SUITES

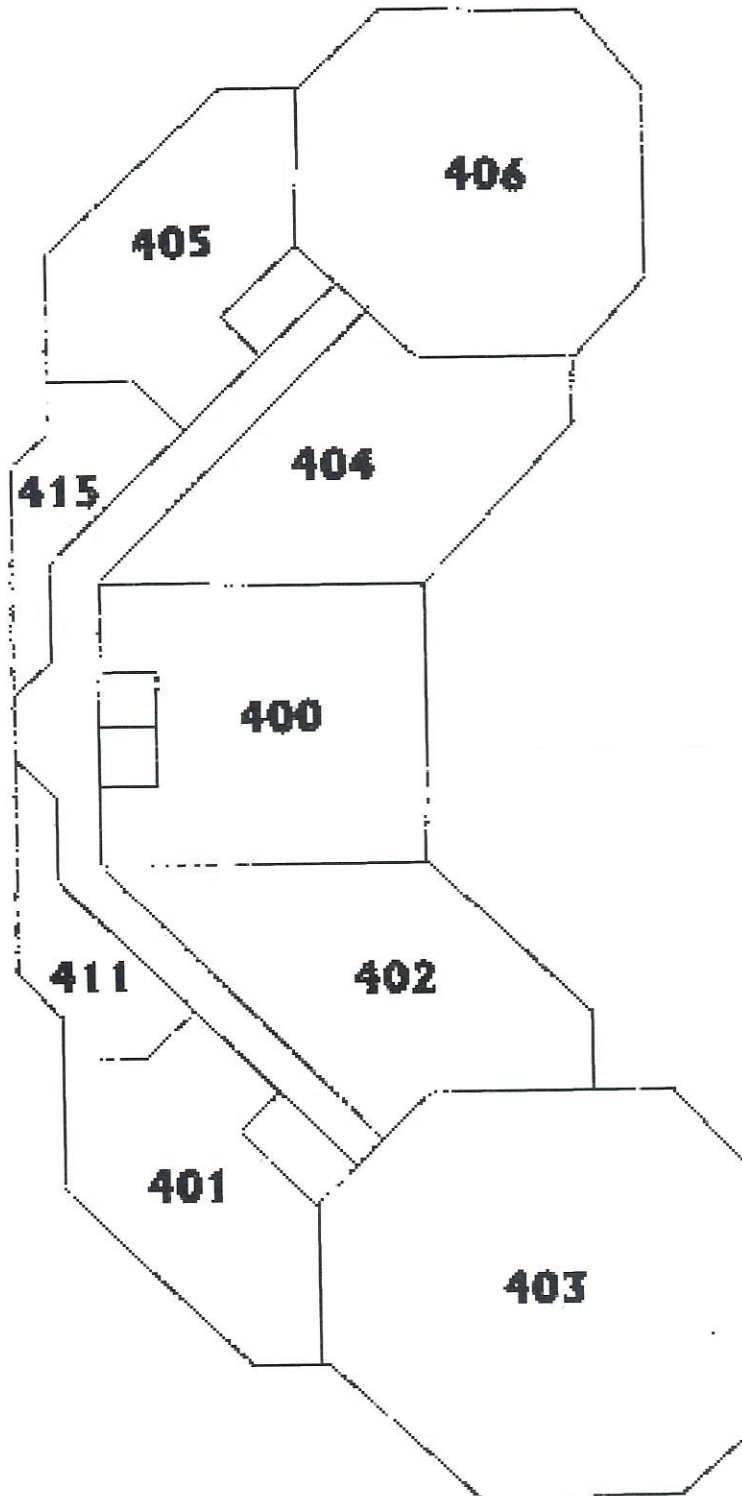



VICTORIA REGENT
WATERFRONT HOTEL & SUITES

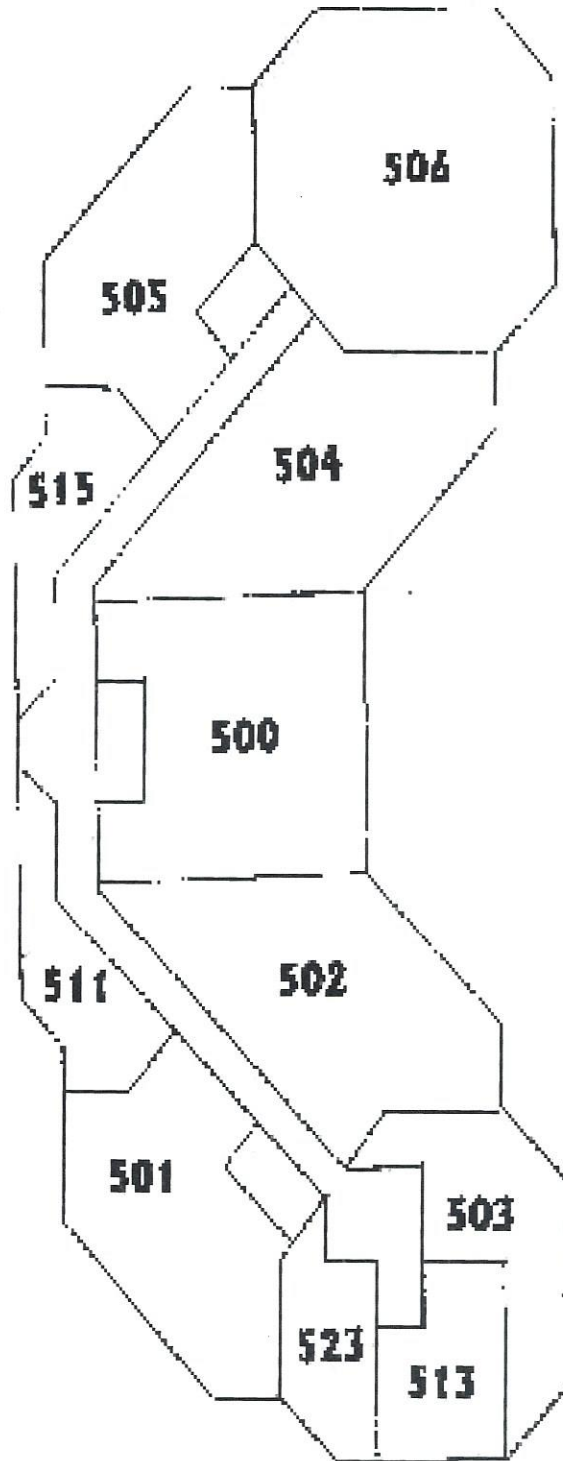



VICTORIA REGENT
WATERFRONT HOTEL & SUITES

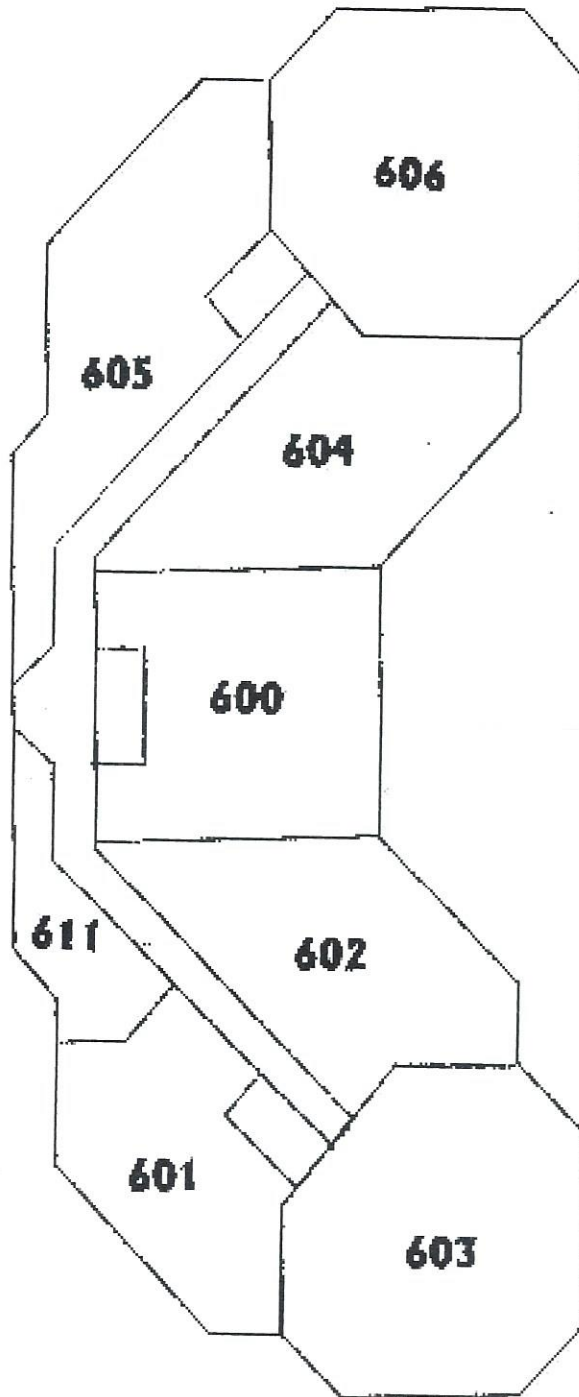



VICTORIA REGENT
WATERFRONT HOTEL & SUITES

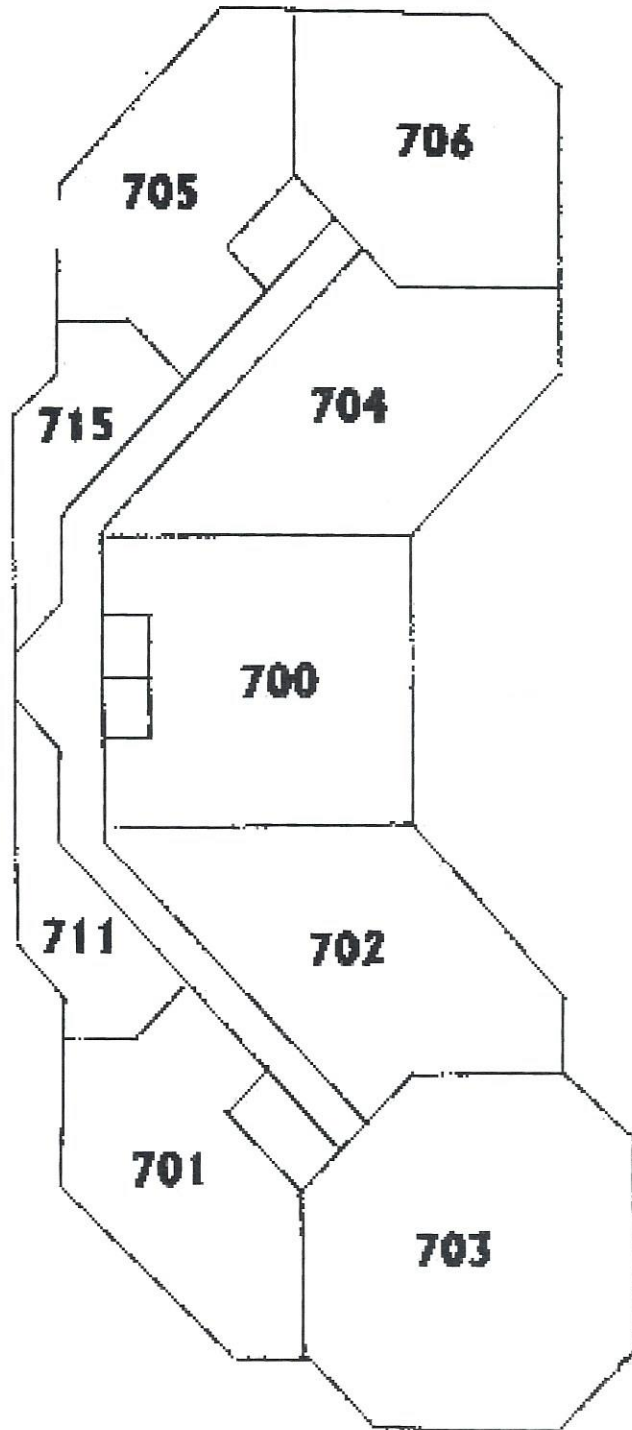



VICTORIA REGENT
WATERFRONT HOTEL & SUITES

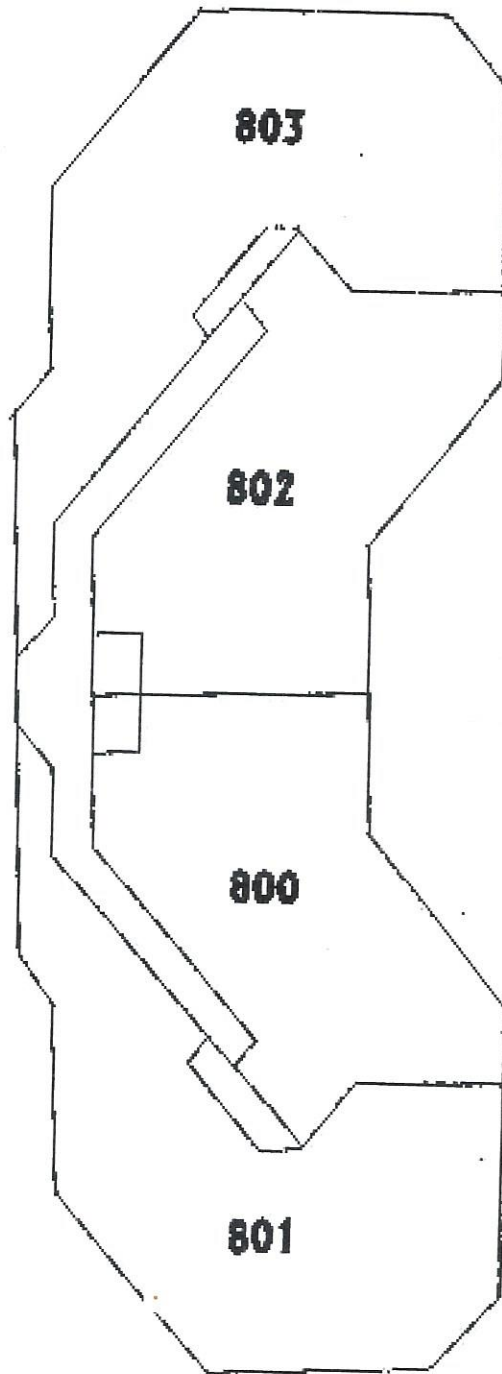

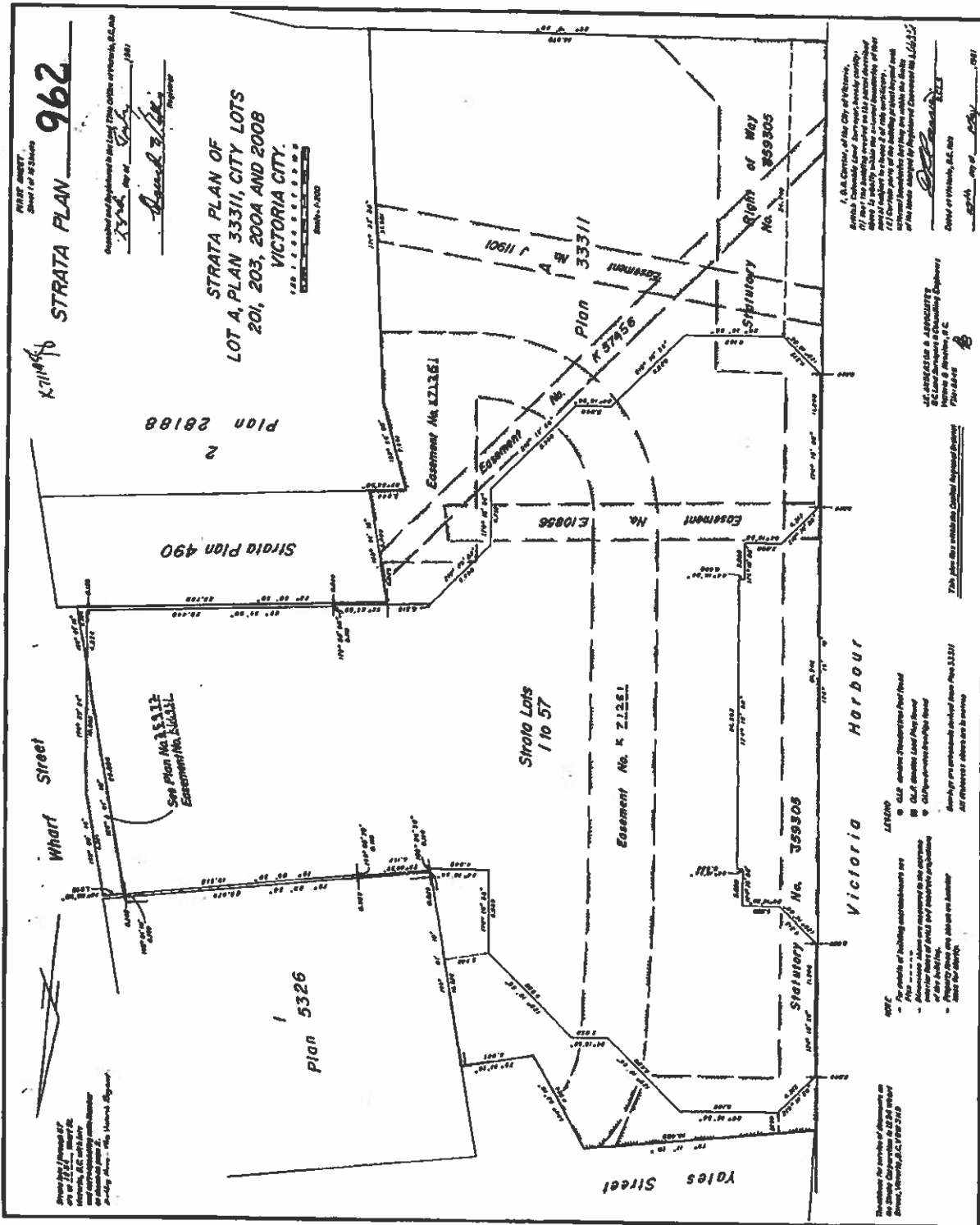

STRATA PLAN 962
 SHEET OF STRATA PLAN

RECEIVED AND APPROVED FOR THE CITY OF VICTORIA
 BY THE CITY ENGINEER
 AND THE REGISTRAR OF STRATA PLANS
 ON THIS DATE: 2008-12-20

[Signature]
 REGISTRAR OF STRATA PLANS

I, S. B. Stevens, of the City of Victoria,
 Surveyor, do hereby certify that this plan
 shows the boundaries and areas of the
 lots and the nature and extent of the
 easements and other interests therein
 and that the same have been duly
 approved by the City Council.
 2008-12-20

[Signature]
 SURVEYOR

NOTES

- For details of building requirements see the City of Victoria Building Bylaw.
- For details of zoning requirements see the City of Victoria Zoning Bylaw.
- For details of the use and occupancy restrictions of the strata lots, see the City of Victoria Strata Act and Regulations.
- For details of the maintenance and repair obligations of the strata owners, see the City of Victoria Strata Act and Regulations.

For further information see the City of Victoria website at <http://www.victoria.ca>.

Maps created by a user. [Learn how to create your own.](#)

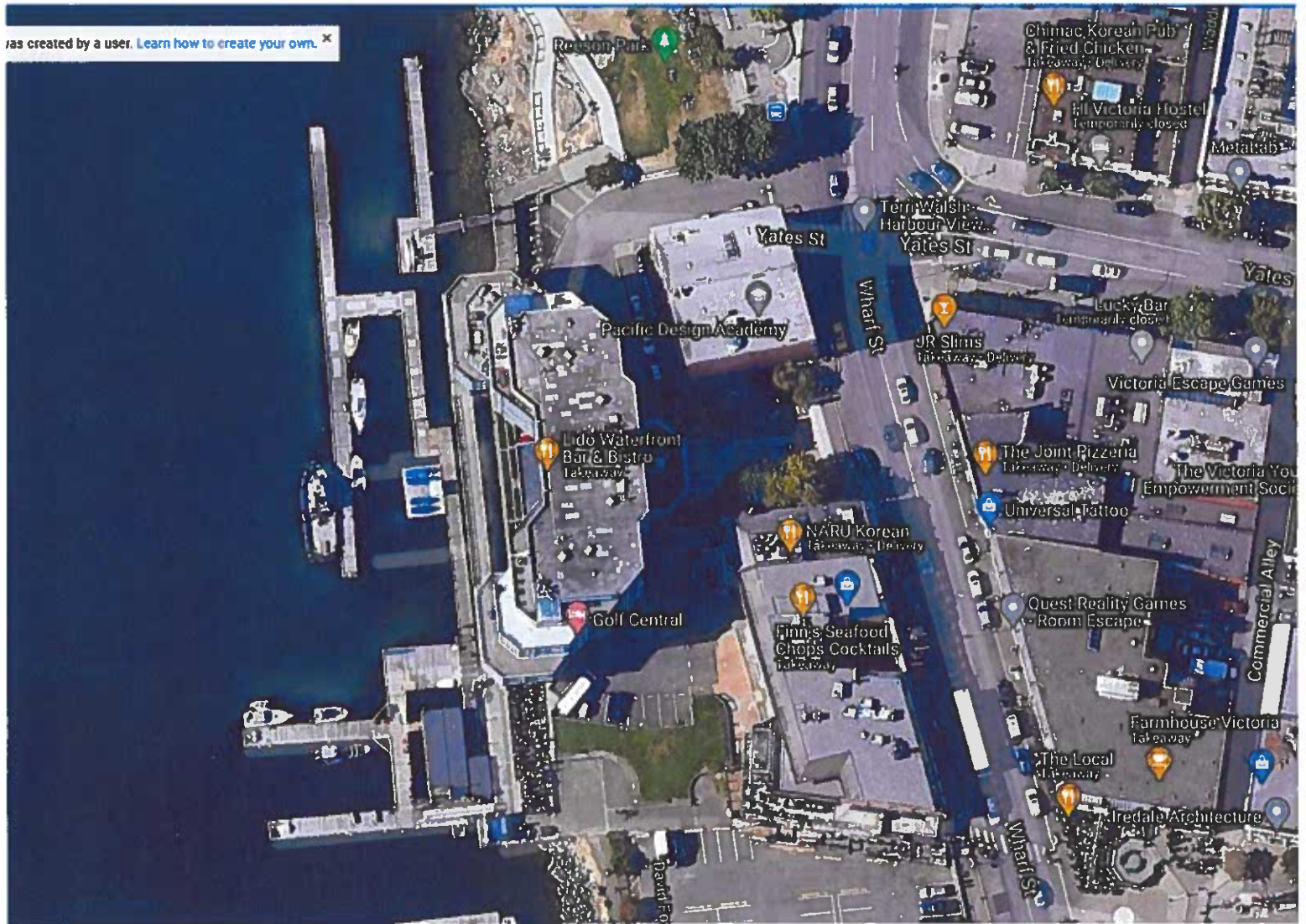



1244 Wharf St
Victoria, British Columbia

Google

Street View

