

1733-37 Fairfield Road

A Proposed Development by Aryze

1733-37 Fairfield Road

We acknowledge with respect the Ləkʷəŋən and WSÁNEĆ peoples on whose traditional territory the property stands and the Songhees and Esquimalt nations whose historical relationships with the land continue to this day.

Overview

- Aryze Philosophy 3
- Project Team 4
- Area Context 5
- Site Context 7
- Policy Context 8
- Project Pillars 9
- What We Heard 13
- Site Layout & Massing 15
- Building Form & Design 17
- Materiality 19
- Green Building Strategies 20
- Renderings 21
- Elevations 23
- Project at a Glance 25
- Floor Plates 27
- Street Views 31
- Mobility Context 33
- Transportation 35
- Community Engagement 37
- Tenant Assistance 38
- Shadow Studies 39
- Landscape Plan 41
- Application Process 43

RE: 1733 Fairfield Rezoning and DP Submission

We are pleased to present this letter outlining the core content of our application to rezone and develop the lands at 1733, 1735 and 1737 Fairfield Road. Enclosed is a summary of a four storey, thirty (30) unit residential strata development, comprising six (6) ground-oriented townhomes and twenty-four (24) single-level residences—ranging from studio to one, two and three bedroom units on the upper floors. The building will include EV-ready surface parking, thoughtfully landscaped grounds, as well as a range of building amenities for owners. We will be seeking to amend these properties from the current R1-G zoning with an OCP amendment to a new site specific (TBD) zoning that could accommodate the development of a low rise multi-residential building.

Since first hosting a preliminary information session on February 28th, 2022—followed by our formal Community Association Land Use Committee meeting on March 28th, 2022—we have received valuable feedback from the community, along with comments from City of Victoria planning staff, including the Advisory Design Panel. This feedback has culminated in some revisions to the proposal, which you'll find detailed throughout this document.

The biggest evolution of the proposal is in the form of the building design. Feedback from the community, staff and Advisory Design Panel was that the 'modern mansard' roof and fishscale metal shingle materials were too dominant and not in keeping with the neighbourhood's form and expression. In response to these concerns, our approach to the project's architectural design has been revised at the upper levels of the building.. This, in turn, has enabled us to provide more housing diversity in the proposal, which now includes a broader range of home types.

While some elements of the proposal have evolved, our original project pillars continue to be emphasized in the design—and in many ways—now exceed what we were able to deliver with the previous proposal. Combined, we believe this proposal focuses on the important tenets of city building: placing the right homes in the right places, thoughtful design that acknowledges the neighbouring context and future growth potential, all while preserving urban greenspaces. We look forward to discussing this proposal with you in more detail as we progress throughout the approvals process.



Chris Quigley
Director of Development
Aryze



Aryze Philosophy

We're an integrated home building, development and urban planning team committed to increasing the quality of homes and communities in Victoria, BC.

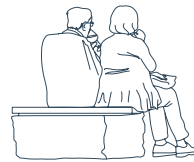

Diversity

A healthy city needs quality housing options across the spectrum, including varying forms of tenure. We build a range of home types, in order to allow new households to form, young families to grow and downsizers to stay in their community.

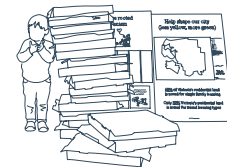

Engagement

Community discussions are a valued benefit to our process. Members of the community are an excellent repository of the aspirations, needs and challenges of the neighbourhoods we work within and engagement is critical to the success of our projects.



Design

We are a close, cohesive team that is aiming to make a big impact on our built environment. Creative architecture and intelligent design add value to the urban fabric that makes our city more interesting, diverse and fun.



Analytics

Building something just for the sake of building isn't good enough. Proprietary data sets inform our decisions, and help us understand how people in urban areas interact with the built environment. Every Aryze home is created with its neighbourhood in mind.

Project Team

Rotunda, Victoria BC



Aryze Developments

We believe that every neighbourhood should have diverse housing types and tenures for all incomes and demographics. With a focus on innovation across a full spectrum of housing types, Aryze's projects include custom homes constructed in partnership with some of Canada's most acclaimed architects, along with creative urban infill developments built in established neighbourhoods you already know and love.

With nearly two decades of home building experience Aryze combines traditional building methods, innovative construction technologies and intelligent design to deliver architecturally-significant multi-family developments which are attainable to more people in their journey along the housing continuum.

aryze.ca

Bowker, Victoria BC

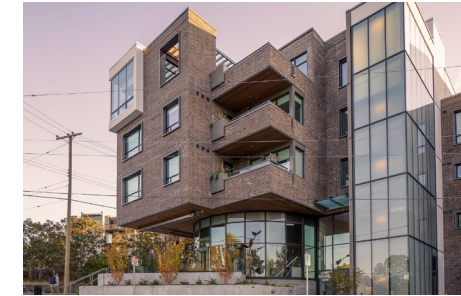

Cascadia Architects

Cascadia Architects is a 14 person architecture studio based in Victoria, British Columbia. The firm's identity is rooted in their combined 40 years of experience with respected and award-winning firms in Victoria and beyond. Cascadia's areas of practice are broad, and include commercial, institutional, mixed use and custom residential, with a focus on urban and infill projects. Attention to good urban design principles and sustainable construction systems inform their methodology.

The spirit of the firm grows from three simple ideas: creative collaboration is fun; beautiful surroundings enhance our daily lives; and it is the role of the architect to weave together the needs and resources of the client, community, and the natural environment to create spaces that are functional and uplifting.

cascadiaarchitects.ca

1326 Pandora, Victoria BC



Biophilia Design Collective

Biophilia Design Collective is a landscape architecture firm with 13 years experience in landscape design, urban planning and project management. Through their experience with residential, commercial and civic projects, they understand the value of achieving goals through innovative design, conservative planning and cost effective implementation measures.

Biophilia believes that exterior landscape and interior green space should respect, enhance and work symbiotically with architecture and be accessible to people of all abilities to help improve health and well-being. Their focus is to create synergies between the soft plantings and the hardscape aspects of the built environments they create that both relate to and enhance the architecture while ensuring accessibility.

biophiliacollective.ca

Area Context

Room to Grow



The neighbourhoods of Gonzales (and adjacent Fairfield) contain a range of housing types, from heritage homes and bungalows to large estate homes and low-rise multi-family residential buildings. That being said, as a highly desirable neighbourhood with room to grow, there is a historic undersupply of housing choice. Additionally the demand for housing has continued to significantly outpace supply forcing many families to look to other neighborhoods for a place to call home. For example when we look at adjacent neighborhoods with comparable statistics, Gonzales is far behind in both population growth and diversity in housing types being built. By providing the right homes in the right places, we keep our neighborhoods vibrant and healthy by encouraging people in all stages of their lives to live in their neighborhood of choice.

Due to the Gonzales neighbourhood being within walking distance of shops, schools, parks/beaches and health care facilities, it is a highly desirable place to live. The proximity to Hollywood Park, beaches, Fairfield Shopping Center, and health care facilities—as well as Fairfield Road being a transportation corridor—means that this is an ideal place for increased housing choice.

Although the area is predominantly zoned for ground-oriented single family homes, the neighbourhood directives outlined in the Official Community Plan envision the exploration of residential intensification opportunities in the areas in and around the Fairfield Shopping Centre Small Urban Village. Areas along the Fairfield Road corridor are particularly suitable for residential intensification since these sites are well connected to key transit routes while also being highly walkable and bike-friendly. The neighbourhoods are known for their access to numerous parks, schools, retail and other service offerings which makes them great places for increased housing choice for our city's growing population.





Legend

-  Subject Site
-  Subject Lots 1733-37
-  Neighbourhood Retail
- 1. Thrifty Foods
- 2. Hollywood Park
- 3. Christ Church Cathedral Pre-School
- 4. St. Matthias Anglican Church
- 5. Margaret Jenkins Elementary
- 6. Hide + Seek Coffee
- 7. Abkhazi Garden
- 8. Carousel Childcare
- 9. Gonzales Park

Site Context



Legend

-  Subject Site
-  Subject Lots 1733-37



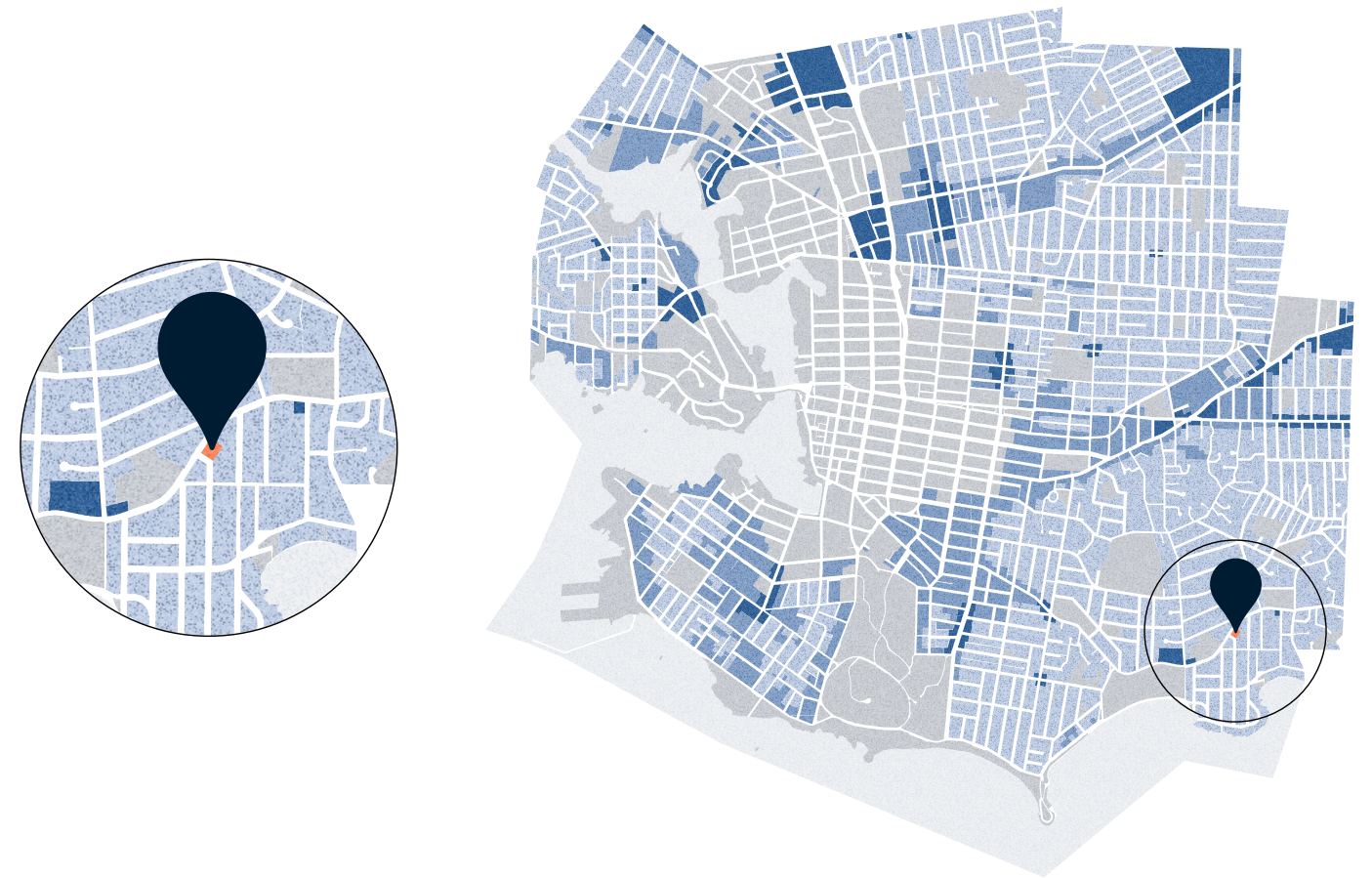

The subject site, located at 1733-1737 Fairfield Road, is a consolidation of three single-family residential properties on the south side of Fairfield, meeting at the corner of Fairfield and Beechwood in the Gonzales neighbourhood of Victoria. Situated along a key transit corridor, the subject site is well positioned to support a growing population and offers many of the day-to-day amenities to promote a '15 Minute City' lifestyle. The site's direct neighbors are primarily single family homes and local businesses. It is across the street from Hollywood Park, which is a favorite amongst recreators and

Rhodo, a townhome development by Aryze that was completed in the summer of 2022. Within walking distance—or short bike ride—you'll find schools, beaches, healthcare facilities, numerous parks and the Fairfield Shopping Centre Small Urban Village.

Policy Context



Legend

-  Subject Site
-  Urban Residential
-  Traditional Residential
-  Urban Villages & Town Centres
-  Others

From a policy context, the subject site holds a Traditional Residential Urban Place Designation and each of the three land parcels that make up this site are currently zoned R1-G for single-family dwellings. At 1.73 FSR, the proposal does exceed the 1.0 FSR density allowance in the Official Community Plan for Traditional Residential. However, for reasons laid out in detail throughout this document, this is a suitable location for an increase in density outside of the Traditional Residential range, and the introduction of a zone allowing for a low-rise multi residential housing type. This

increase in density enables our proposal to include a mix of housing types ranging from studios to three bedrooms plus den which are intended to meet the needs of a greater variety of people at different stages of their life and welcome new families to the neighborhood. This is an important tenet outlined in the Gonzales Neighbourhood Community Plan and one that is central to this proposal.

Project Pillars

Our 1733-37 Fairfield Road proposal has been developed with the consideration of three key project pillars—defining elements responded to through design.

Key Pillars

The Right Homes in the Right Places →
Thoughtful Design →
Preserving Green Space →

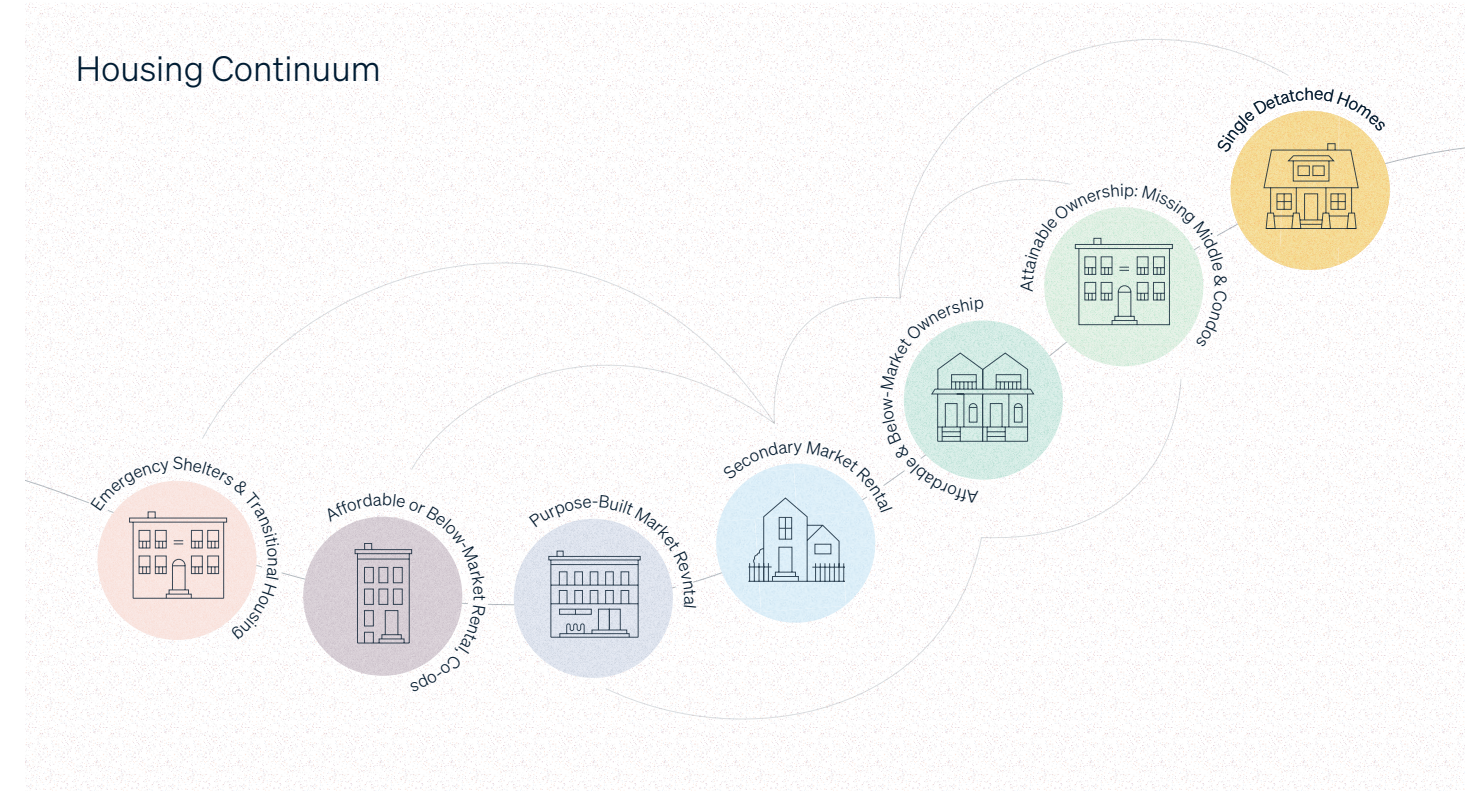

The Right Homes in the Right Places

The major challenge all growing cities and neighbourhoods are facing is: where should we locate housing to respond to population growth and the changing demographics of established neighbourhoods? It is widely understood that homes should be located near existing services, amenities and other destinations (in areas such as this Fairfield corridor). Locations like these are great candidates for more housing as they demonstrate an efficient use of urban infill land that avoids clearcutting forests on greenfield sites in order to provide the homes people need. The City's policies speak to these trends with a whole host of strategies that aim to reduce car dependency, showcase climate leadership and promote

diverse housing choice in existing neighbourhoods. At Aryze we seek to provide a diversity of housing options in our city that will support Victoria's development as an inclusive, diverse and resilient community. In the short time we have been a business we have worked on an array of duplex schemes, mid-rise apartments—and most recently—the nearby Rhodo townhouse development, located across the street from 1733-37 Fairfield Road. The evolution of this proposal further emphasizes our dedication to this concept, as we have revised the unit mix to include a broader demographic of home buyers beyond the downsizer audience which was originally the main focus for this development.

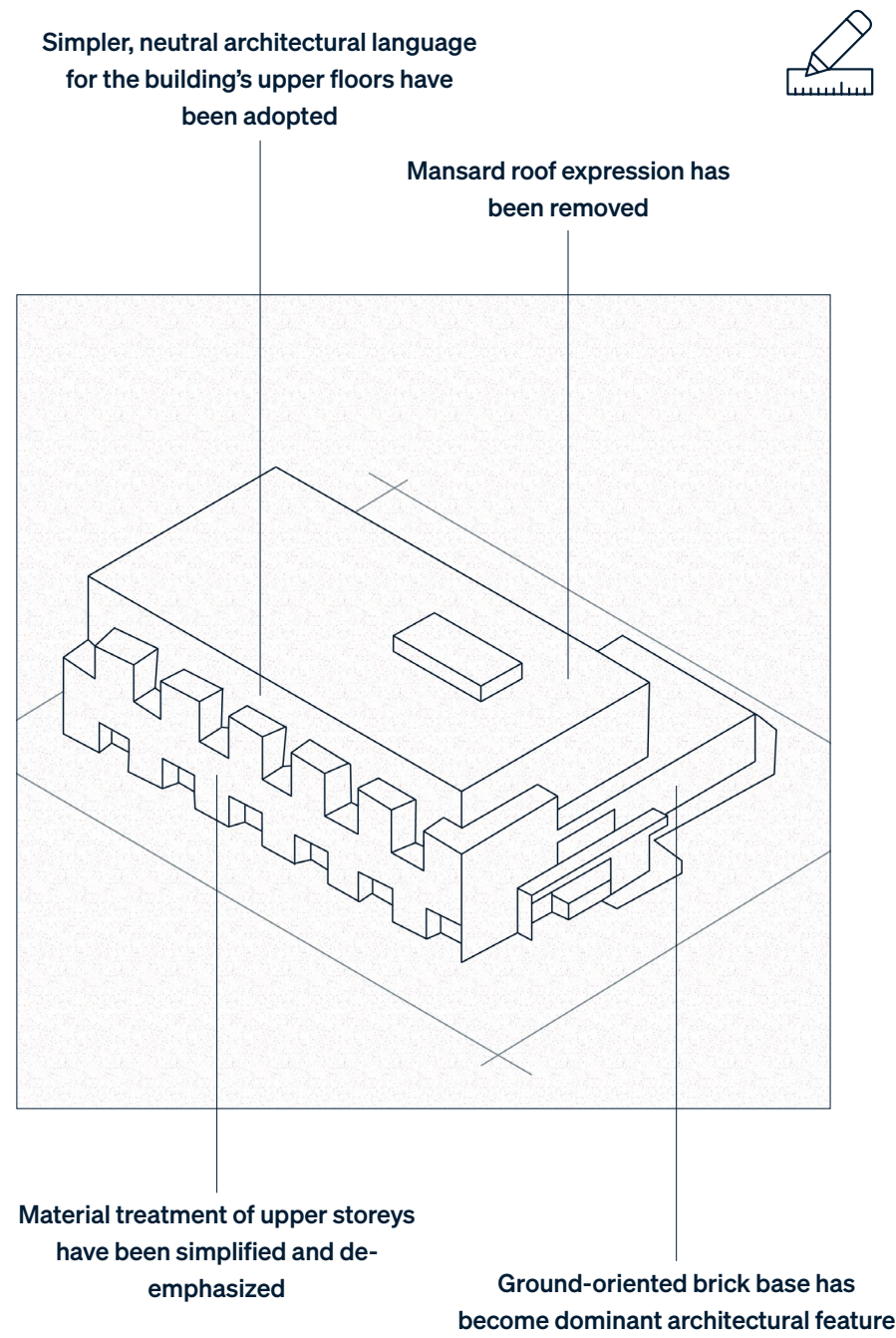

Thoughtful Design

The concept of ‘thoughtful design’ speaks to our design drivers from a variety of perspectives. First, it speaks to the value of purpose-built and purpose-designed spaces, like these, which have been envisioned with a specific local community audience in mind. Identifying this audience at the outset of our proposal development allows us to acutely address their day-to-day lifestyle needs through design. In this case, not only are we ensuring there are housing options with single-level living, but also units that could be modified to become adaptable if required. Second, ‘thoughtful design’ speaks to the key moves that have been implemented when looking at the overarching site context and complementing the existing neighbourhood grain.

Throughout the evolution of this proposal, we have engaged with the neighbourhood, Council and staff to receive feedback related to the design and how to ensure serve the needs of the community. We have taken these comments into consideration on several aspects of the building such as height, roofline, materials and landscaping. By gathering this information and making the necessary adjustments we were able to create a space that better fits the needs and wants of the neighbourhood, while aligning with key policy objectives.

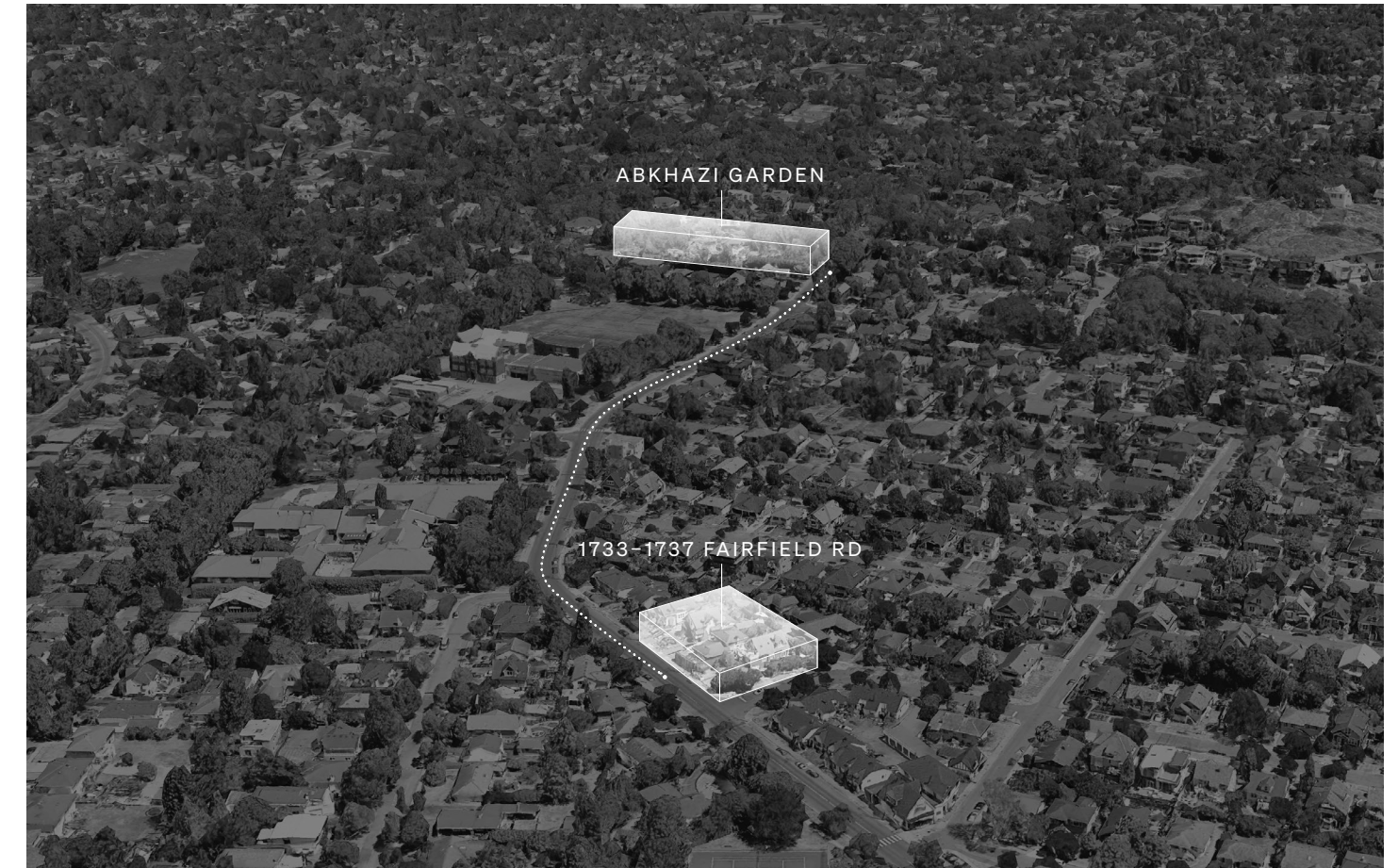

Preserving Green Space

An important component of this proposal is the long-term preservation of neighbourhood green space through the use of a density transfer. While the concept may seem new to Victoria, a density transfer (or density bonusing) is a common tool used in cities across North America, often where heritage buildings can sell their development rights in order to protect their heritage status. Those zoning rights can be realized by someone else and the density moved to a more appropriate location.

In this instance, Abkhazi Garden is acting as the donor site with the land at 1733-1737 Fairfield Road being the receiver site of the density rights. The density transfer will officially downzone the entire Abkhazi Garden lands to a zone that preserves the site's current activities while also ensuring that the site receives its official heritage designation. Of the available 35,000 sqft of density available from the Abkhazi Garden site, our proposal uses 39% of the density with the balance being released and secured as a financial donation for The Land Conservancy of BC.

What We Heard

Throughout our engagement process, we received valuable feedback from residents. At times this means balancing competing priorities to arrive at evidence-based planning and design solutions that will respond to the planning objectives and embrace the future potential and overall housing needs of our City.

Here we have summarized what we have heard from our dialogue with the community to provide considered responses from the project team. Where we are changing our plans based on community feedback, we have identified these changes. The following sections outline the key themes of the stakeholder feedback we've received to date, along with the project team's response to each theme or area of interest.



Housing Diversity

We have heard concerns about the lack of diversity in housing options within the Fairfield/Gonzales neighborhood, which consists primarily of single family homes. As our population and demographics change, we need to build housing that suits the current needs of our community. By redesigning the building to provide a broader variety of unit types and sizes at different price points, the homes will inherently suit a broader range of lifestyles and demographics including individuals, couples, families and seniors.

This is a positive evolution to the proposal, as we believe that every neighbourhood should have diverse housing types and tenures for all incomes and demographics. A densified, compact, walkable lifestyle is critical to solving our climate and housing crisis; all while creating more livable and healthier communities.



Roof Form/Design

Our feedback from the community, staff and Advisory Design Panel was that the 'modern mansard' roof and fishscale metal shingle materials were too dominant and not in keeping with the neighborhood's scale and expression. In response to these concerns, our approach to the project's architectural design has been substantially revised. The mansard roof has been removed and replaced with a conventional flat roof which de-emphasizes the building's upper floors. The material palette has been revised to a more aesthetically familiar finish with different points of interest such as the brick treatments, metal cladding and wood finishing. In making these modifications to the top floor we have the added benefit of changing the floor plans to increase housing diversity within the building and layer in attainable housing options.



Attainable Housing

Changing the design of the building to include more housing diversity allows us to assist more people in their homeownership journey, thus providing them the opportunity to enter into a housing market—and neighbourhood—that may traditionally be out of reach. Currently, many first-time home buyers and young families who want to live in the Gonzales neighbourhood are not able to find a home that is within their budget range, forcing them to look elsewhere for housing. By offering a range of housing choice in an established neighbourhood with room to grow, we can help build a community with a diversity of incomes, lifestyles and demographics.



Parking Capacity

We understand that parking capacity is a concern for neighbours, so we executed a Parking Capacity Study to examine the availability of parking in the nearby area. Bunt & Associates' On-Street Vehicle Parking Supply and Demand Study concluded that the observed area has a total of 81 parking spaces with a peak observed demand of 40 spaces (49%). There are 41 resident only parking spaces within an approximate one-block area from the site and peak demand periods only reduced availability by 16 spots, leaving 25 vacant spaces available. There are 31 publicly available parking spaces within an approximate one-block area from the site and these spaces had a maximum observed demand of 19 spaces which equates to 61% occupancy—approximately 12 vacant vehicle spaces.

Site Layout & Massing

Step 1

What We Heard

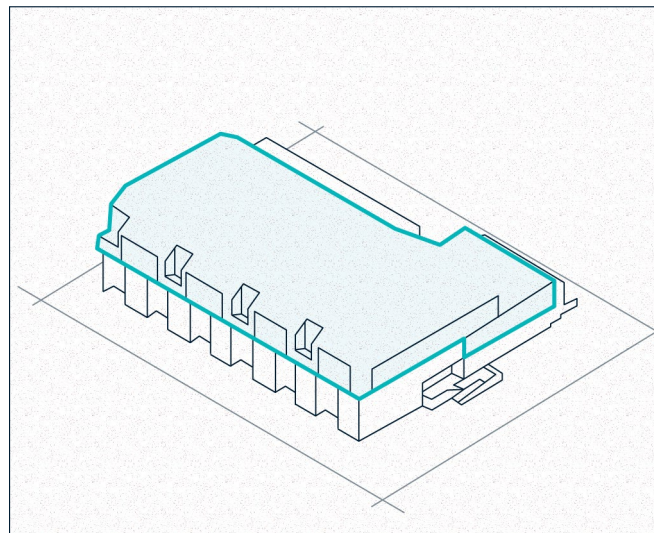

- The projecting walls at level 3 are too dominant and increase the building's perceived height and massing.
- The complex geometry of the proposal's roof creates an aggressive look and feel.
- The fishscale materiality is out of keeping with the surrounding residential neighbourhood.

Step 2

Step 2

Simplify the Roof

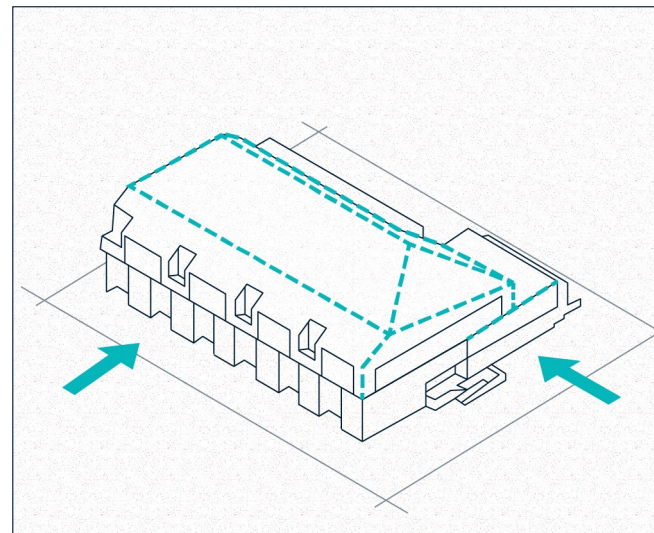

- Reduce the visual complexity of the proposal's roofline, creating a calmer and less dominant expression to its upper floors.
- Step the proposal's upper floors back at the 3rd and 4th levels.

Step 3

Articulate the Base

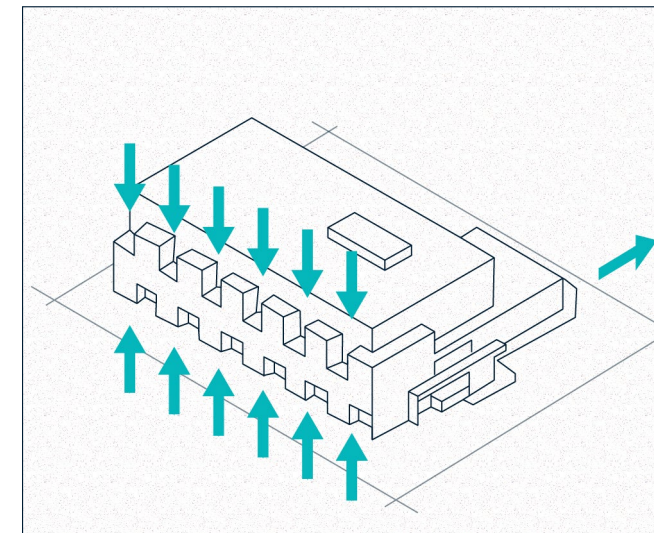

- Create a distinctive 2 and 3 storey language of alternating brick bays along Fairfield Road.
- Extend the brick material palette along the full extent of the Beechwood Avenue frontage.

Step 4

The Results

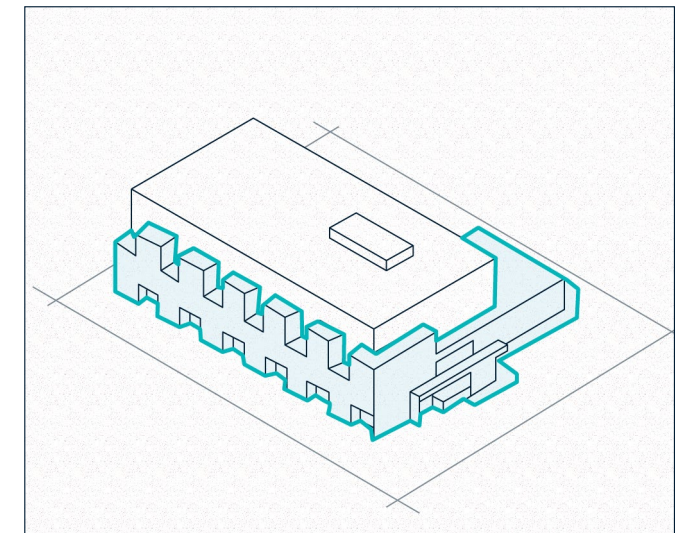

- The mansard and gable end wall roof expression have been removed and a simpler, neutral architectural language for the building's upper floors have been adopted.
- The material treatment of upper storeys have been simplified and de-emphasized.
- The upper storeys step back from the building face.
- The building's ground oriented brick base becomes its dominant architectural feature.

Building Form & Design

The proposed architectural expression is understated elegance that sensitively responds to site context and meaningfully contributing to the overall neighborhood aesthetic.

The previous projecting mansard expression with gable end wall entirely was redesigned to a conventional flat roof with parapet construction approach. The four storey volume therefore steps back considerably from the building face, in alignment with the Design Guidelines for Multi-Unit Residential Buildings, de-emphasizing the prominence of the Proposal's upper floors from its primary aspects. The Project's proposed brick treatment has become its new primary means of articulating human scale. A rhythmic A-B pattern of two and three

storey brick volumes with picket guards along Fairfield Road provide visual interest along this frontage in lieu of the variegated dormers and mansard roof formerly dominating this elevation. At the corner of Beechwood Avenue and Fairfield Road, the three storey brick base transitions downwards to a two storey volume, appropriately weighting the brick's mass at this prominent corner and transitioning to a smaller scale towards the lower density residences behind. Variations in brick coursing, transitions in brick depth, and a unique

brick screen detail at the project's primary residential entrance provide further emphasis on this high quality, durable material and visual interest to the project as a whole.

Mechanical units have been relocated to the roof adjacent to the elevator overrun. These units are screened in metal matching the Project's exterior finish, and located away from the building's edges in order to avoid significant sightlines from adjacent properties and the public realm.



Materiality

Materials



Light Brick

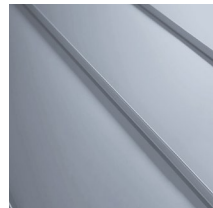

Metal Standing Seam

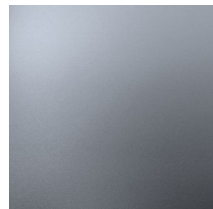

Prefinished Metal

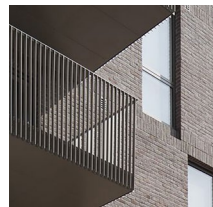

Metal Picket Guard

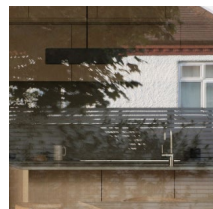

Glazing

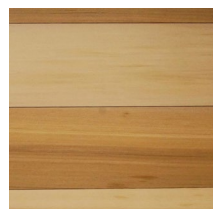

T&G Wood

The material palette has been revised to a more aesthetically familiar and contextually sensitive standing seam and flat panel metal finish from the previous fishscale metal material palette. Instead the emphasis is weighed on the two and three storey brick base and de-emphasizing the impact of the third and fourth storey metal clad volume behind and above.

The primary residential entrance includes a vertical wood grain finish and is protected by a projecting brick clad canopy. The wood finish creates a warm, rich quality to the residential entrance while the projecting brick canopy balances the Beechwood Avenue elevation with appropriate weight and emphasis on the pedestrian realm in relation to the stepped back metal clad volume above.

The material treatment of Levels 1 to 3 has been partially revised at the NE and SE facing elevations. It is now clad in a metal finish in keeping with the proposed treatment of Levels 3 and 4 at all elevations, more suitably tying to this newly proposed material concept and allowing for the concentrated application of brick to the Project's highly prominent aspects at Fairfield Road and Beechwood Avenue. Continuous planters are proposed at the southernmost balcony and outdoor common area located on Level 3. These planters buffer the balconies from Beechwood Avenue, the adjacent residential property, and the parking area, providing a softened edge and visual interest in this location.

Green Building Strategies

Transit-Oriented Infill Development

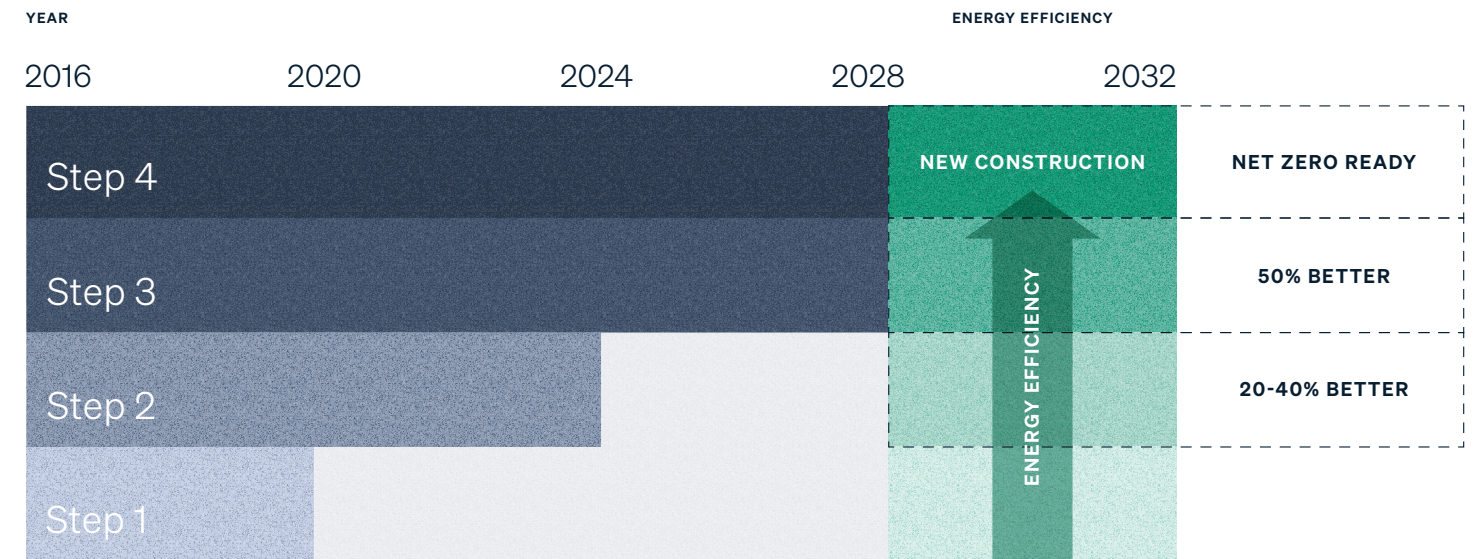

Transit-Oriented Infill Development

With the growing body of research indicating that densification holds the key for cities' fight against climate change, reducing our dependence on cars is the most significant component of reducing greenhouse gas emissions. The central location of 1733-1737 encourages a car-lite lifestyle, offering alternative transportation modes like walking, cycling and transit as primary options for future residents. In order to achieve our long term climate goals we must make decisions now that will create a more sustainable future.

High-Performance Building Envelope

1733-1737 Fairfield Road is designed and constructed to BC Step Code 3, in accordance with the City of Victoria's phased Step Code guidelines which were updated as of January 1st, 2020. Step Code 3 represents an incredible 50% increase in efficiency. This includes designing the building systems in a way that will reach high levels of performance in Thermal Energy Demand Intensity (TEDI), Total Energy Use Intensity (TEUI), and airtightness. Overall, this works to successfully improve energy efficiency and reduce energy costs.

100% Electric Building

The single biggest sustainability measure is our decision to proceed with a comprehensive renewable energy supply. This will result in a major reduction of GHG emissions produced during the building's operational lifetime—a meaningful contribution to the City's efforts to respond to the causes and impacts of climate change. 1733-37 Fairfield Rd will set a strong example of a low carbon, high performance condominium building in alignment with the principles and targets outlined in the City of Victoria Climate Action Plan.

Renderings

Beechwood Elevation Perspective



Fairfield Pedestrian View



Elevations

Beechwood Avenue

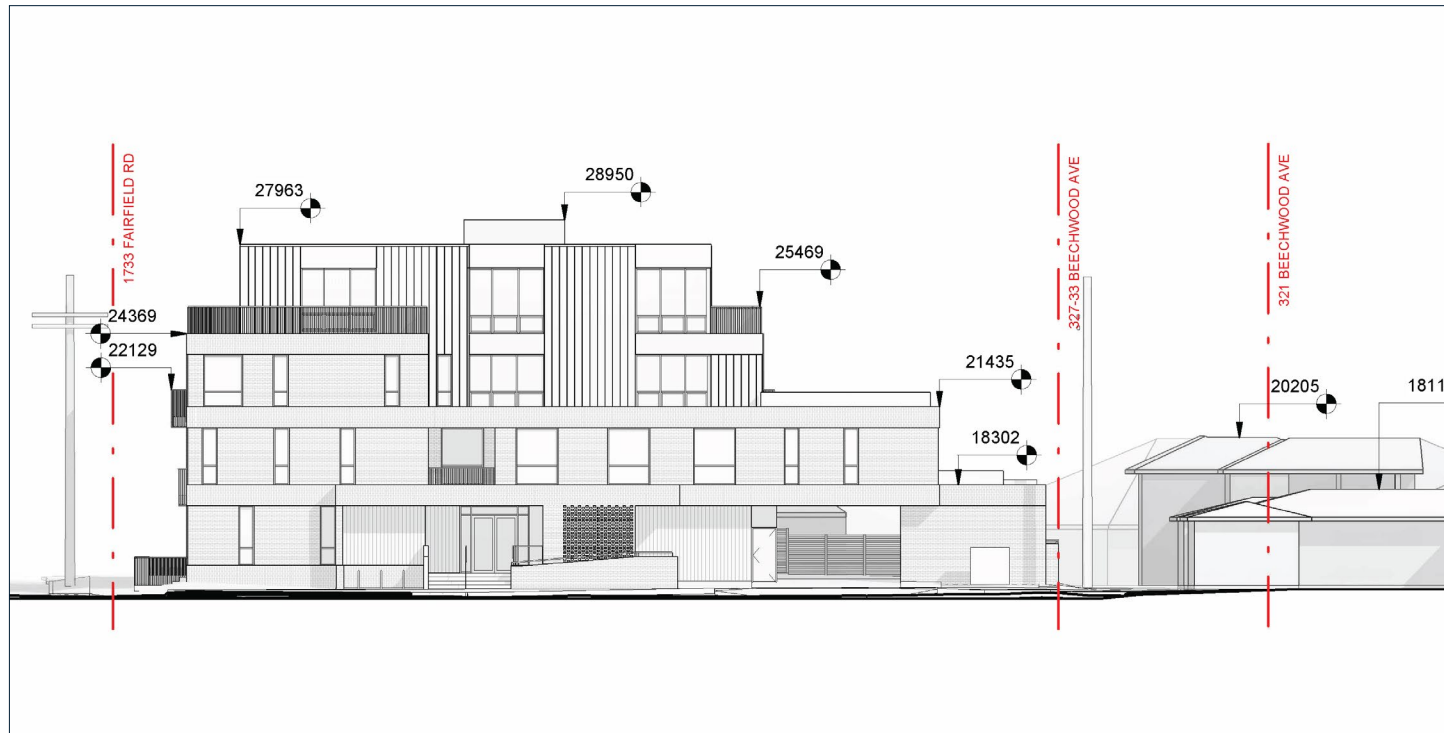

North Elevation



Project at a Glance



Height

4 storeys



North Setback

2.33m



Number of Homes

30 Homes



Short-term Bike Stalls

6 Stalls



Unique Features

- Oversized storage lockers for residents
- Zero-Carbon/100% Electric HVAC and hot water delivery systems
- The building will target (and in some areas exceed) BC Step Code 3 energy efficiency standard

Site Area

18,751 sqft

East Setback

2.62m

Townhomes

6 Townhomes

Long-term Bike Stalls

54 Stalls

Floor Area

32,132 sqft

South Setback

0.50m-4.78m

Studio

2 Homes

Parking Stalls

23 Stalls
(2 Van Accessible)

FSR

1.71 FSR

West Setback

2.73m

1 Bedroom

13 Homes

Car Share

Modo Car Share

Site Coverage

65%

2 Bedroom

3 Homes

2 Bedroom + Den

4 Homes

3 Bedroom

2 Homes

Residential Tenure

Strata Ownership

Floor Plates



Ground Level



Level 2

Floor Plates

Level 3

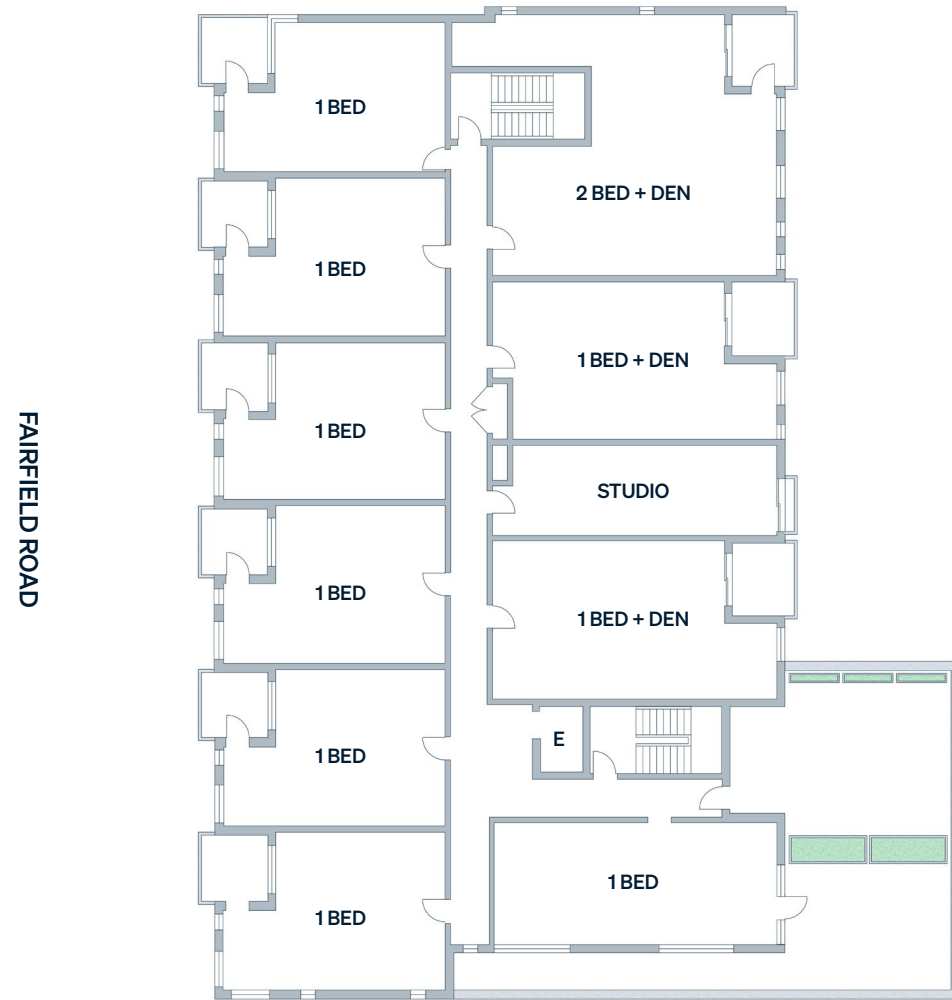

BEECHWOOD AVENUE



Level 4

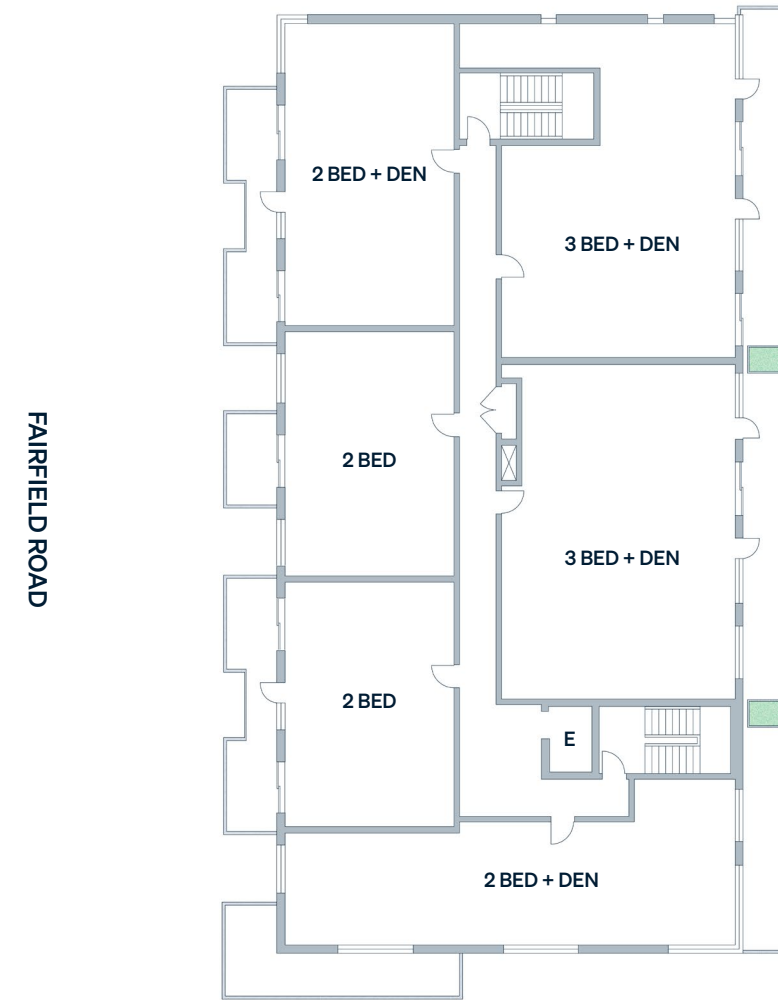

BEECHWOOD AVENUE



Street Views

Fairfield Road



Beechwood Avenue



Mobility Context

The site is located centrally within the Gonzales neighbourhood and is well connected to Oak Bay village centre to the north-east and approximately 3km to downtown Victoria to the west.



Road Network

The area is well served by local, collector and secondary arterial road networks. The immediate neighbourhood is made up of short neighbourhood blocks, which is indicative of a fine grain road pattern. This road design allows for ease of movement through the area as there are multiple connectivity options in all directions. From the subject site, east/west movements are captured by Fairfield Road, which connects to Cook Street and Downtown, while Foul Bay Road connects to the north/south. These corridors are mere steps away from the proposed development at 1733-1737 Fairfield Road and serve as the main corridors for vehicles, buses, pedestrians and cyclists alike.



Car-Lite Lifestyle

Overall, the central location of this subject site lends itself well to a car-lite lifestyle. Being in close proximity to numerous amenities as well as being located on a central transportation corridor with ample cycling and pedestrian pathways—makes alternate modes of transportation not only attractive, but preferable. As such, the proposal has been designed to encourage walking, cycling and transit as the primary transportation options for future residents. In addition to providing 24 EV ready parking stalls, we have included 52 secure bike stalls (including both standard and oversize/cargo bike stalls). The project will be providing a new car share vehicle which will benefit the new residents of the project and the wider community. Looking ahead, we anticipate future residents of 1733-1737 Fairfield Road to be making an increasing number of trips on foot to meet their daily needs as the local services and retail amenity options expand or use the provided car share rental program when longer trips are required. Curiously, when we surveyed residents of our Rhodo development we found that 77% of residents only own 1 car, 61% live and work in the same neighborhood, and 33% bike or walk as primary mode of transportation.



Cycling Networks

The site is well connected to both walking and cycling networks. All streets surrounding the development have side walks on both sides. Fairfield Street and Crescent Road are signed bike routes. Downtown can be accessed in 15 minutes via Fairfield Street or via the nearby Richardson Street to the north. Continuous bike lanes on Foul Bay Road and Henderson Road provide residents with a direct cycling route to Camosun College Lansdowne Campus and the University of Victoria. Plans call for the existing signed bike routes to be upgraded and protected creating a continuous, AAA cycling route that connects the site's neighbourhood to Victoria's downtown area. With its substantial volume of bike parking, the proposed development at 1733-1737 Fairfield Road is well positioned to support the anticipated cycling demand.

Transportation

Transit Network

1733-1737 Fairfield Road is well served by public transit, with three transit routes within 800 metres of the site (an approximate 10 minute walk). The site is located less than 200m from stops on regional route #7, and 600-800 m from stops on local routes #1 and #3. Downtown or the University of Victoria is approximately a 16-minute trip on route #7 from the site, and Camosun College's Lansdowne Campus is an approximate 14-minute trip. The table above shows the transit routes and bus frequencies (in minutes) that service this site.

Anticipated Traffic and Parking Impacts





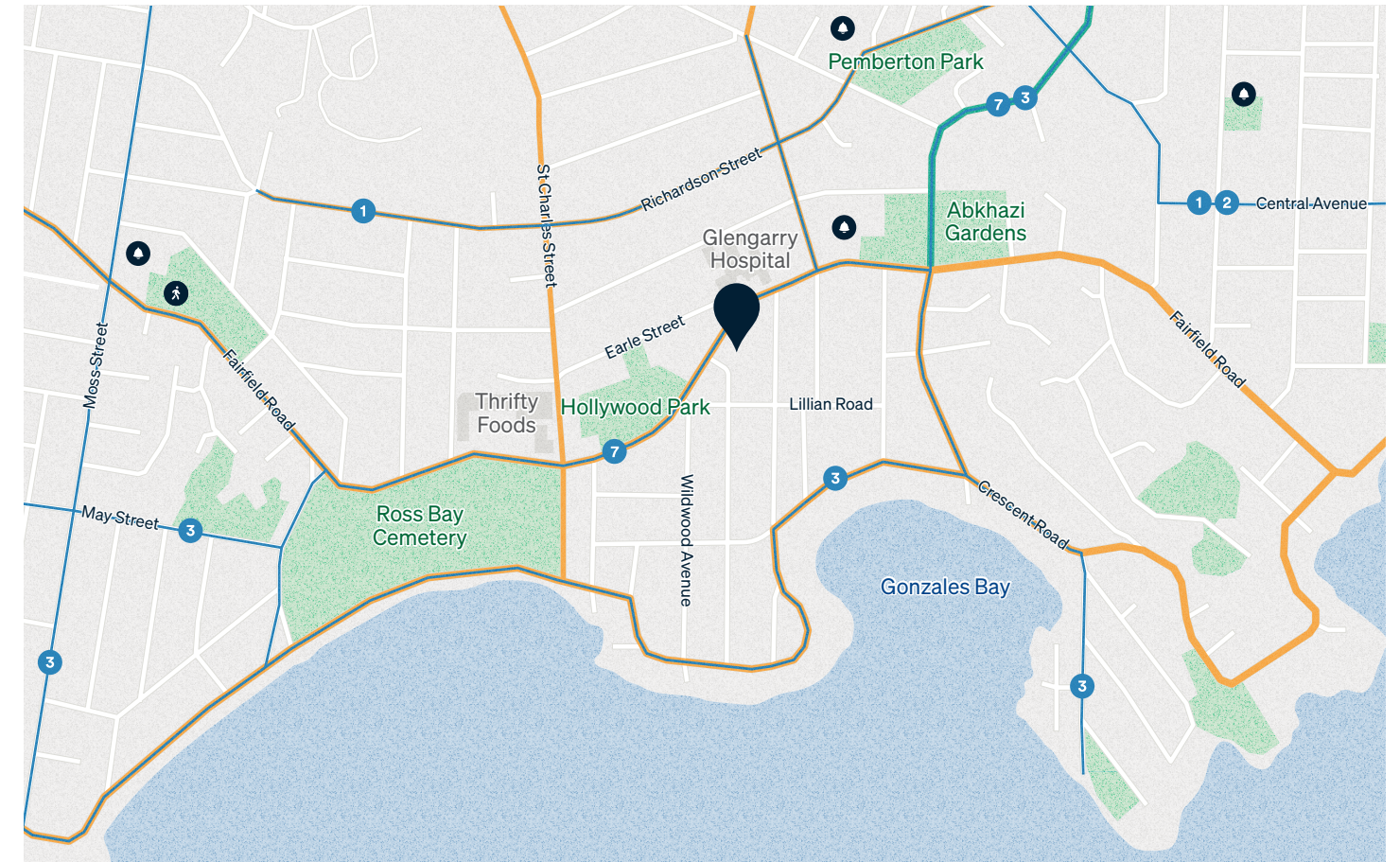

The proposed 30 unit, 4-storey, building would have a trip rate of 0.4 vehicle trips per unit per weekday PM peak hour (Institute of Transportation Engineer Trip Generation Manual). This means that approximately 12 vehicle trips will be entering or exiting the site per peak hour. This quantity of vehicle traffic results in a negligible impact on the local road network and is not anticipated to have a significant impact on adjacent road operations. Additionally, we collected data as to the parking availability in close proximity to the site. During peak periods less than half of the available parking spaces were being utilized thus over 40 spaces remained open for residents and guests.

Route Frequency

#	Bus Route Name	AM	Mid-Day	PM	Evening	Weekend
1	South Oak Bay / Downtown	45	-	45	-	-
3	James Bay / Royal Jubilee	30	65	30	-	60
7	UVic / Downtown	15	20	15	30	30



Legend

-  Subject Site
-  School
-  Recreation Centre
-  Bus Routes
-  Shared Streets
-  Bike Lanes/Road Shoulders

Community Engagement



Our Commitment

We are committed to being good neighbours and having honest, open dialogues within the communities where we do our work. We are available to discuss project details with stakeholders through a variety of channels to build trust and shared vision for the project all while maintaining a respectful and open conversation. Our goal is to create an atmosphere where people feel comfortable to share their ideas, hopes and aspirations for the community.

Timeline

- 11 February 2022 → Neighbourhood letter distributed to neighbours
- 14 February 2022 → Preliminary CALUC event postcards delivered
- 28 February 2022 → Digital CALUC invitation sent to online registrants
- 28 February 2022 → Preliminary CALUC and presentation
- 01 March 2022 → Density transfer proposal press release
- 01 March 2022 → Abkhazi Garden Community Information Session (CIS)
- 10 March 2022 → Formal CALUC event postcards delivered
- 14 March 2022 → Digital CALUC invitation sent to online registrants
- 28 March 2022 → Digital CALUC invitation reminder sent to online registrants
- 28 March 2022 → Formal CALUC and presentation
- 08 April 2022 → Digital CIS invitation: Density Transfer Partnership
- 12 April 2022 → Density Transfer CIS event hosted by The Land Conservancy
- 12 December 2022 → Letter distributed detailing project additions and revisions
- 03 February 2023 → City of Victoria resubmission notification letter distributed to neighbours
- 13 March 2023 → CALUC #2 Event Postcards delivered
- 13 March 2023 → Digital CALUC invitation sent to online registrants
- 27 March 2023 → Digital CALUC invitation reminder sent to online registrants
- 27 March 2023 → CALUC #2 and Presentation

Tenant Assistance

The Aryze policy is to exceed the TAP program requirements in both offers of financial assistance (for rent and moving expenses), but also by offering numerous opportunities for relocation throughout our many purpose-built rentals (PBRs) across Victoria.

We're working closely with the City and their Tenant Assistance Policy on a number of projects, allowing us to take a proactive approach for those who require relocation support.

maintain ongoing communications with the tenants so they feel informed and supported throughout the relocation process.

The official TAPs support has commenced alongside the submission of our Development & Rezoning Permit Applications and we continue to

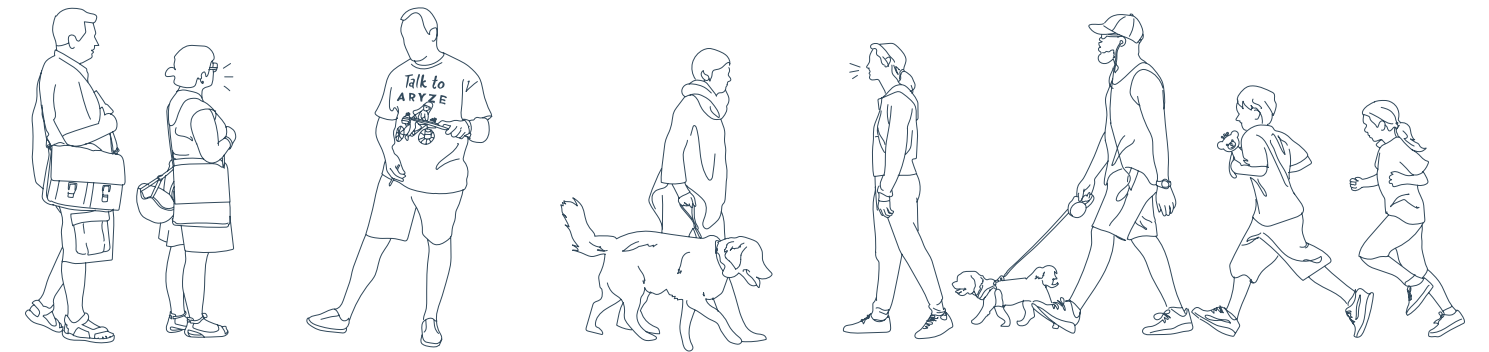

Shadow Studies

Existing

Summer Solstice 9:00am

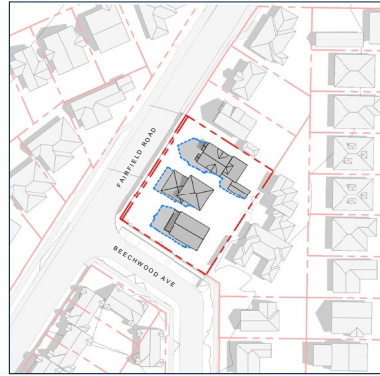

Equinox 9:00am

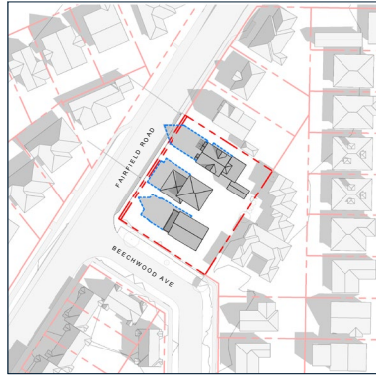

Winter Solstice 9:00am



Summer Solstice 12:00pm

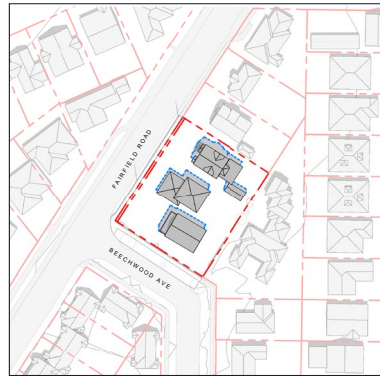

Equinox 12:00pm

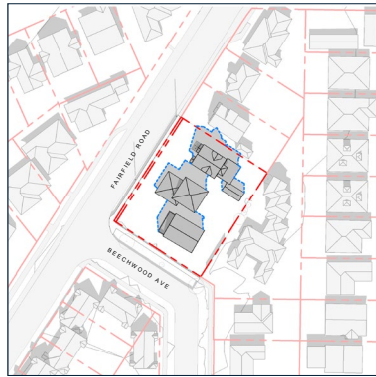

Winter Solstice 12:00pm



Summer Solstice 4:00pm

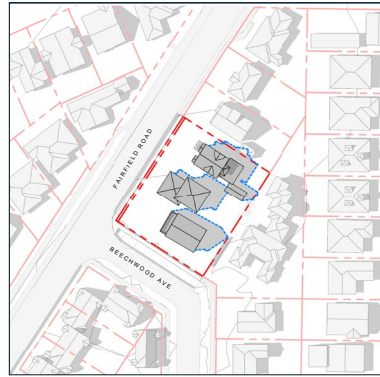

Equinox 4:00pm

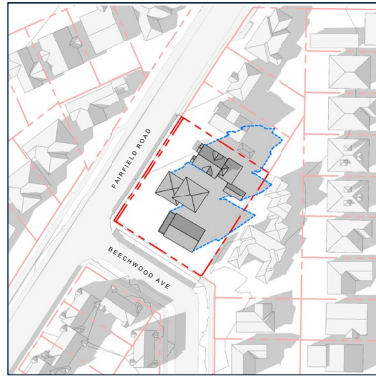

Winter Solstice 4:00pm

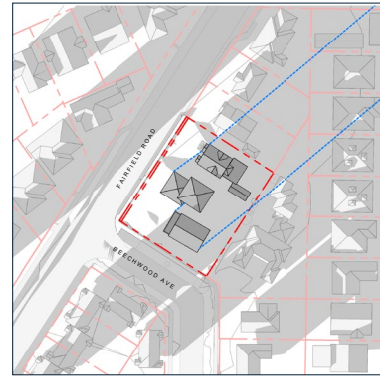

Proposal

Summer Solstice 9:00am

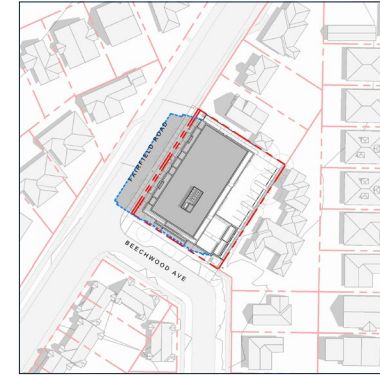

Equinox 9:00am

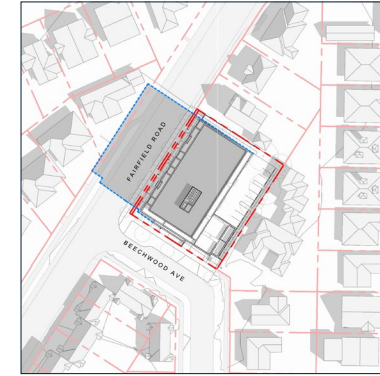

Winter Solstice 9:00am

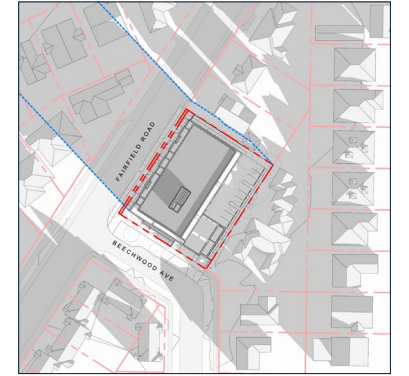

Summer Solstice 12:00pm

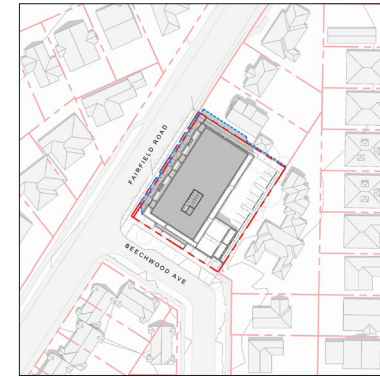

Equinox 12:00pm

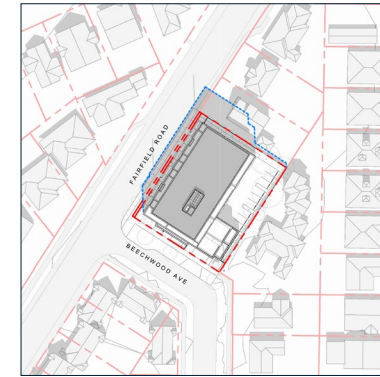

Winter Solstice 12:00pm

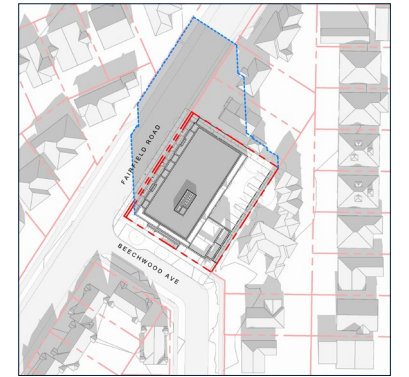

Summer Solstice 4:00pm

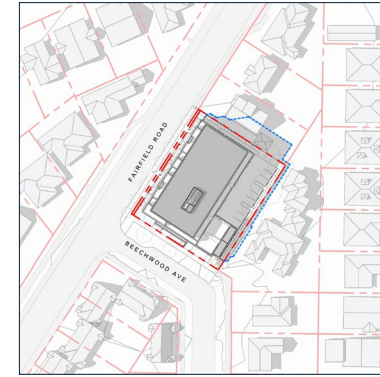

Equinox 4:00pm



Winter Solstice 4:00pm

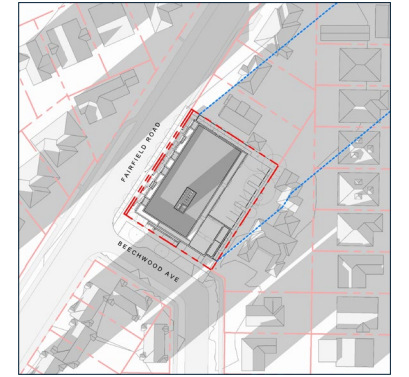

Landscape Plan

The landscape design proposed seeks to create a public streetscape that enhances the pedestrian experience while providing an enjoyable green space in private residential spaces.

Ground Floor Plan

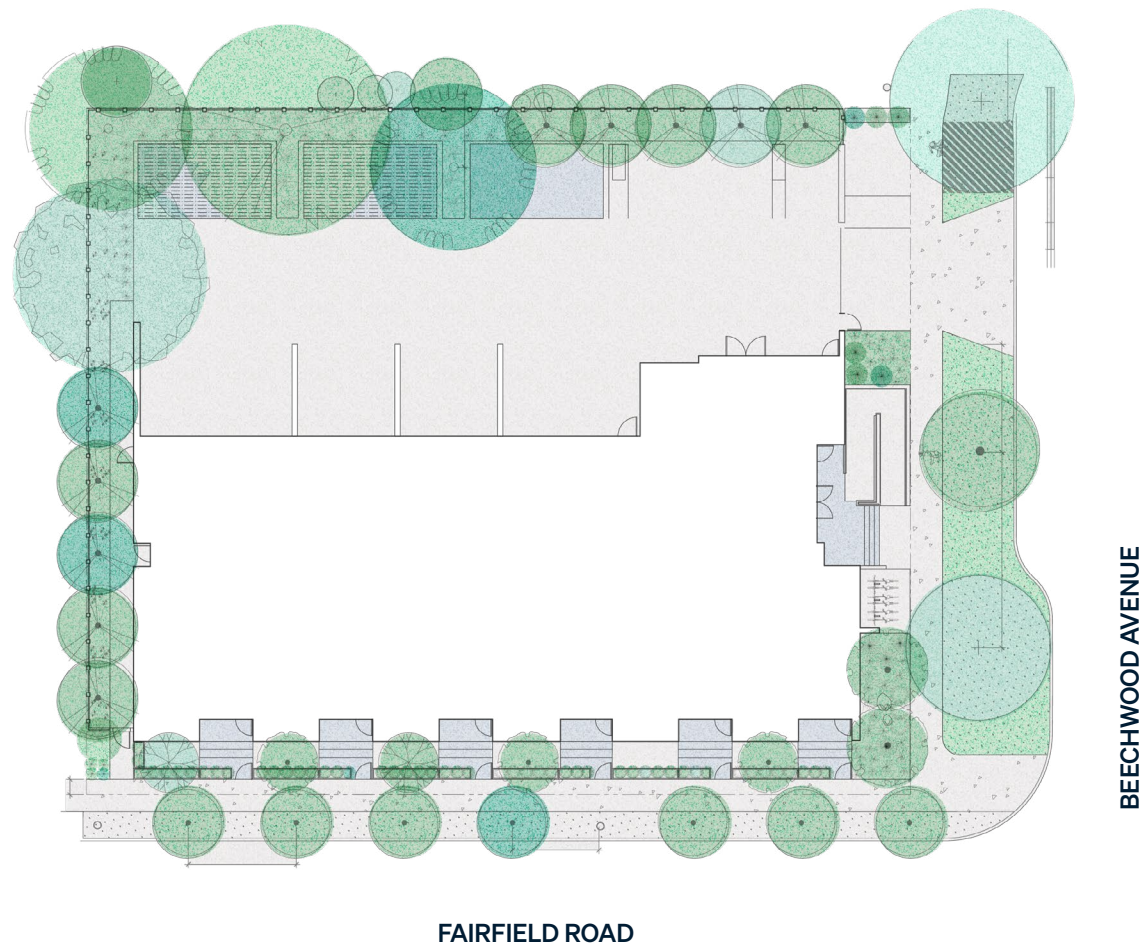

Trees



Paperbark Maple



Autumn Applause White Ash

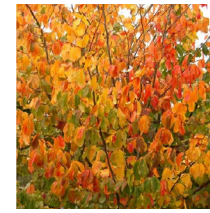

Ruby Vase Persian



Tulip Tree



Japanese Maple



Pin Oak

Plantings

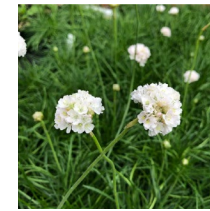

White Flowered Thrift

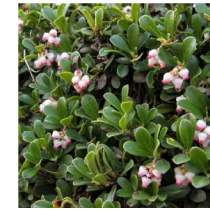

Kinnikinnick



New Zealand Hair Sedge



Spreading Plum Yew



Mexican Orange Blossom



Chinese Silver Grass



Dwarf Purpletop

Application Process

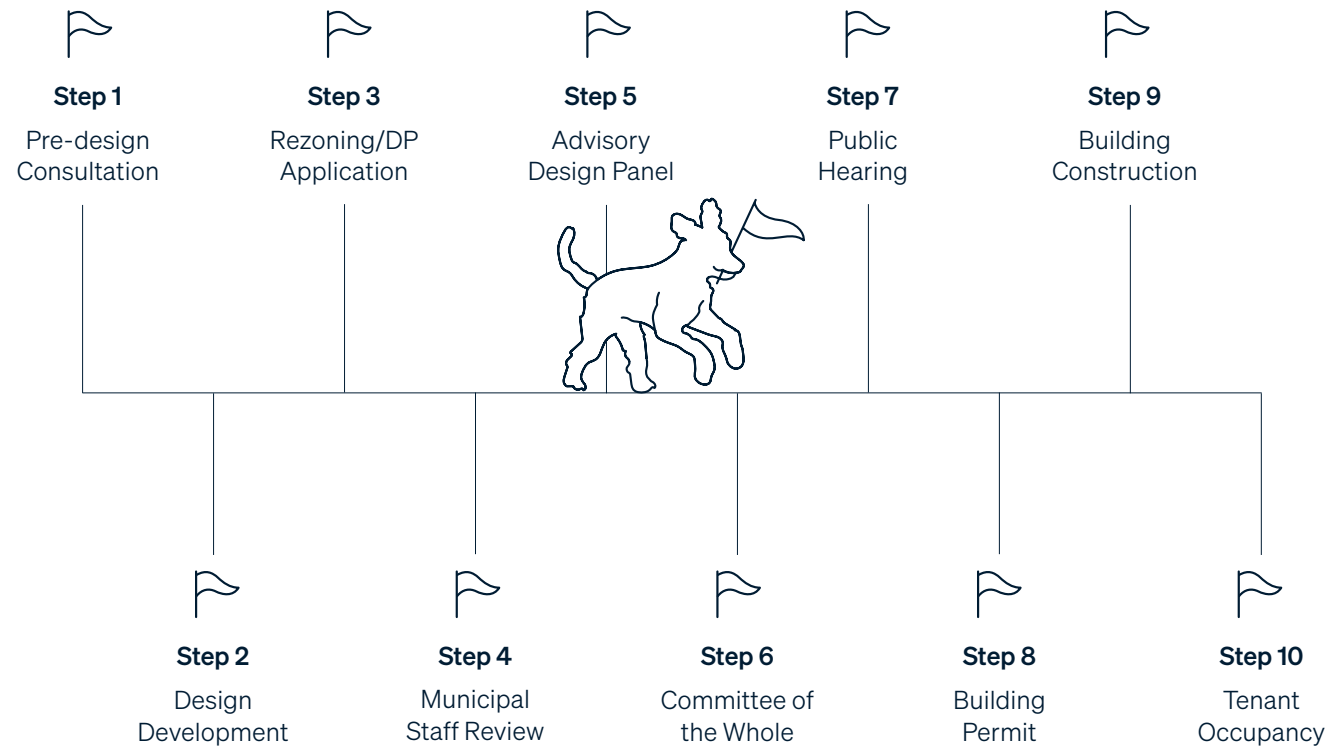

Contact

Aryze Developments
1839 Fairfield Road
Victoria, BC V8S 1G9

(250) 391-2038

Register Online

aryze.ca/1733fairfield ↗

1733-37 Fairfield Road

A Proposed Development by Aryze